

REV.	DESCRIPTION	DATE
1	PRELIMINARY	Sep. 20, 2018
2	WATERPROOF LEVEL	Oct. 05, 2018

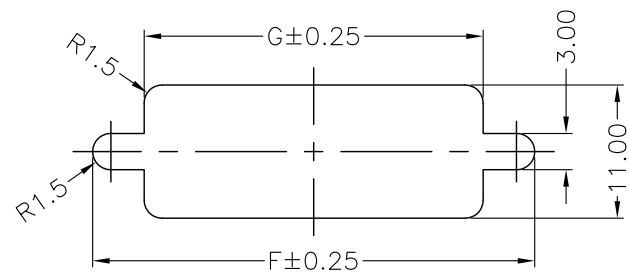
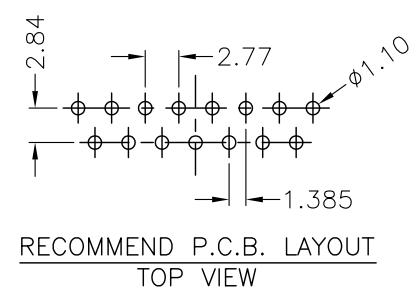
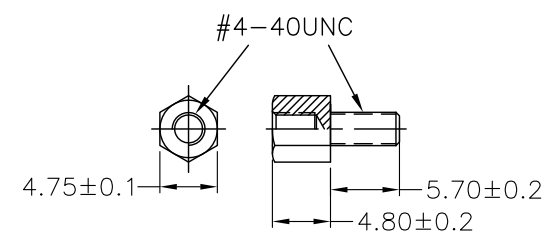
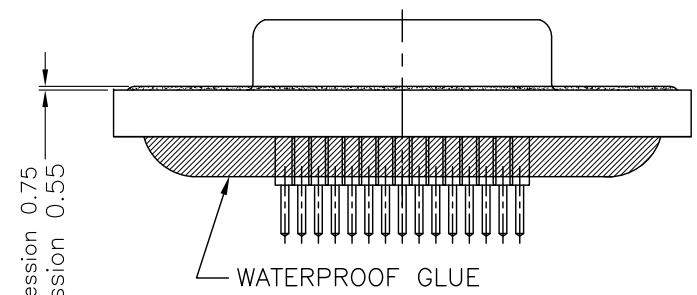
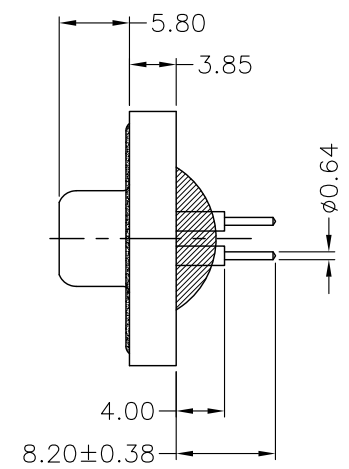
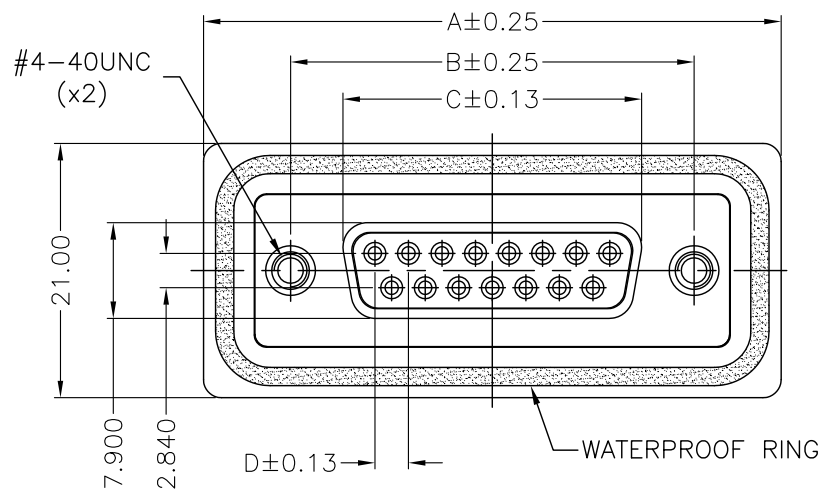

RECOMMENDED PANEL CUT-OUT
PANEL THICKNESS = Between 1.2~2.0mm

MATERIALS

- HOUSING : P.B.T, (UL 94V-0), BLACK.
- TERMINAL : BRASS, GOLD FLASH PLATED OVER NICKEL
- SHELL : SPCC, NICKEL PLATING.
- BOARDLOCK : COPPER ALLOY, TIN PLATING.
- RIVET : COPPER ALLOY, NICKEL PLATING.
- WATERPROOF RING : SILICA GEL.
- WATERPROOF GLUE : EPOXY.
- SCREW : COPPER ALLOY, NICKEL PLATING.

SPECIFICATION

- CURRENT RATING : 5 AMP./PIN MAX.
- RATING VOLTAGE : 250V AC MAX.
- DIELECTRIC WITHSTANDING VOLTAGE : 1000V AC R.M.S. FOR ONE MINUTE.
- INSULATION RESISTANCE : 5000M OHMS MIN.
- CONTACT RESISTANCE : 10m OHMS MAX.
- OPERATING TEMPERATURE : -55°C TO +85°C.
- WATERPROOF LEVEL : IP-X7
- SCREWING TORQUE : 3.0Kgf./cm MAX.

PART NUMBER INFORMATION :

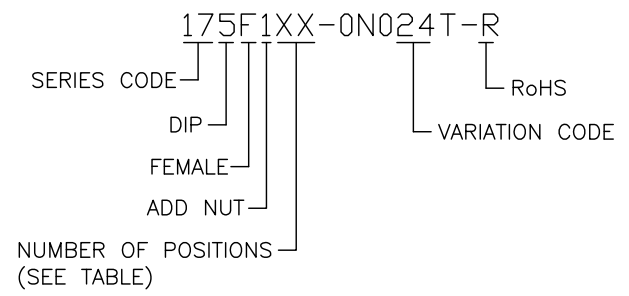

(TABLE)

PIN	A	B	C	D	F	G	Mating Force	Unmating Force
9P	39.40	24.99	16.33	2.77	28.20	20.00	6.4Kgf Max.	1.2Kgf Min.
15P	47.70	33.32	24.66	2.77	36.50	28.00	10.8Kgf Max.	2.0Kgf Min.
25P	64.50	47.04	38.38	2.77	51.00	41.50	17.3Kgf Max.	3.2Kgf Min.

TOLERANCE		DRAWER		Astron WWW.ASTRON.COM.TW
.0=±		NFOLE		
.00=±0.25		CHECK		
.000=±0.13		ALAN		
.0000=		APP'D		NAME
ANG.=±3°		ERPE		
		PRODUCT SPEC.		DRAW NO.
		—		
UNITS : mm		SHEET		07002
SCALE	SIZE	1 OF 1	REV.	
NONE	A4		2	