

REV.	DESCRIPTION	DATE
A	RELEASE	Nov. 01, 2019
B	MODIFY	Jan. 04, 2022

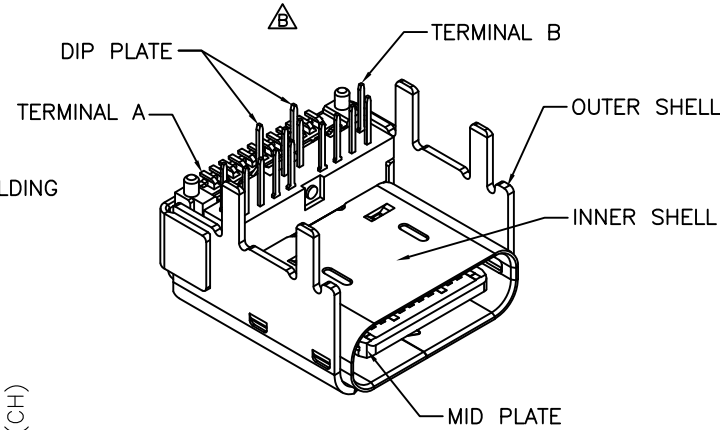
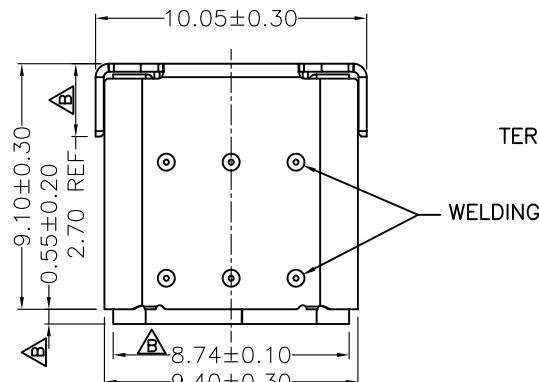

### MATERIALS

- HOUSING : L.C.P E130i (UL 94V-0), BLACK.
- TERMINAL : C7025,(t=0.12mm), GOLD PLATED ON CONTACT AREA, GOLD FLASH PLATED ON SOLDER TAIL, UNDER NICKEL PLATED OVER ALL.
- DIP PLATE : SUS301,(t=0.15mm), NICKEL 50u" MIN. PLATING.
- MID PLATE : SUS301,(t=0.15mm).
- INNER SHELL : SUS304,(t=0.20mm).
- OUTER SHELL : SUS304,(t=0.30mm), NICKEL 50u" MIN. PLATING.

### SPECIFICATION

- CURRENT RATING :  
5A for VBUS (A4,A9,B4,B9)  
1.25A for Vconn PIN(B5)  
WITH RETURN PATH THROUGH THE CORRESPONDING GND PIN(A1,A12,B1,B12).  
0.25A for ALL OTHER PIN
- DIELECTRIC WITHSTANDING VOLTAGE :  
100V AC R.M.S. FOR ONE MINUTE.
- INSULATION RESISTANCE : 100MΩ MIN.
- CONTACT RESISTANCE : 40mΩ MAX.
- OPERATING TEMPERATURE : -55°C ~ +85°C.
- INSERTION FORCE : 5~20N
- EXTRACTION FORCE : 8~20N
- DURABILITY : 10,000 CYCLES.

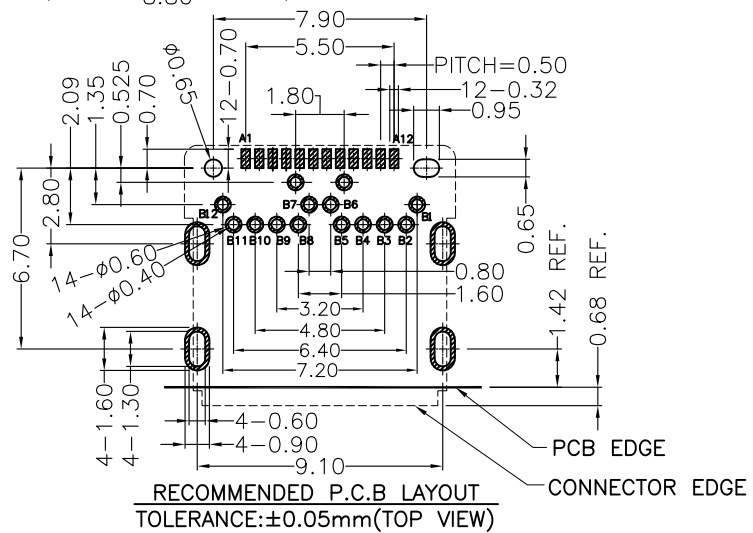
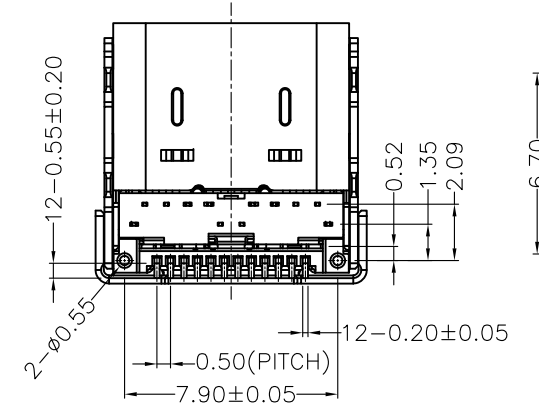
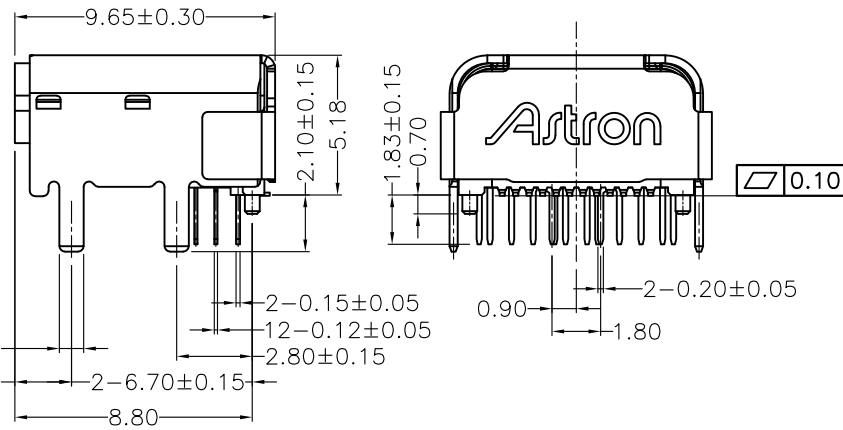
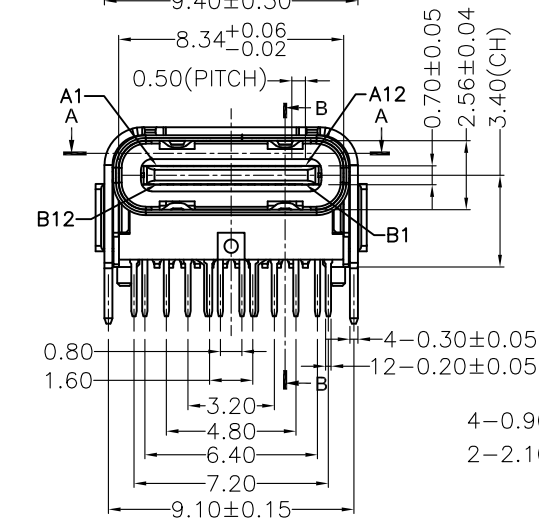

### PART NUMBER INFORMATION :

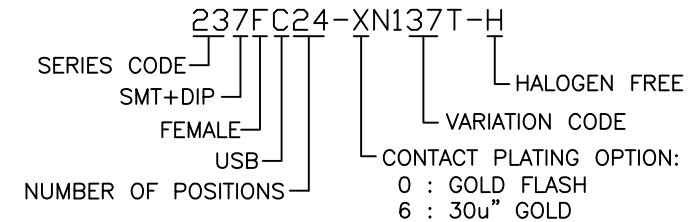



TOLERANCE		DRAWER		 <b>WWW.ASTRON.COM.TW</b>
.0=±0.25		LJF		
.00=±0.15		SRFB		
.000=±0.05		APP'D: ALAN		
ANG.=±3°		PRODUCT SPEC.		NAME: USB C TYPE FEMALE HIGH RISE : CH=3.40mm SMT+DIP TYPE
UNITS : mm		DRAW NO.		237FC24-XN137T-H
SCALE: NONE	SIZE: A4	SHEET: 1 OF 3	REV.: B	T0123

REV.	DESCRIPTION	DATE
A	RELEASE	Nov. 01, 2019
B	MODIFY	Jan. 04, 2022

PIN ASSIGNMENTS

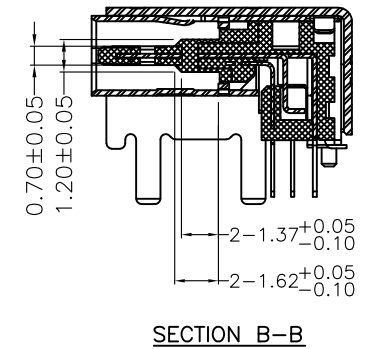
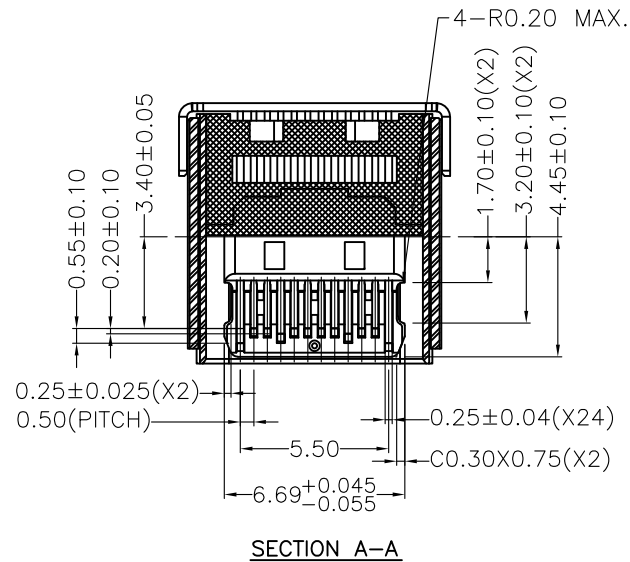
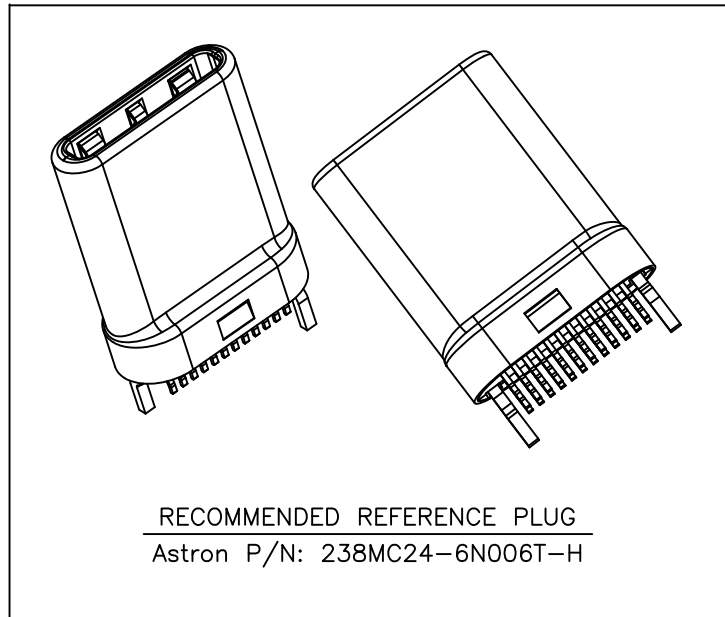
A12	A11	A10	A9	A8	A7	A6	A5	A4	A3	A2	A1
GND	Main Link 0+	Main Link 0-	VBUS	SBU1	USB2.0(D-) USB3(TX-)	USB2.0(D+) USB3(TX+)	CC1	VBUS	Main Link 2-	Main Link 2+	GND
GND	Main Link 1+	Main Link 1-	VBUS	VCONN	USB3(RX+)	USB3(RX-)	SBU2	VBUS	Main Link 3-	Main Link 3+	GND
B1	B2	B3	B4	B5	B6	B7	B8	B9	B10	B11	B12

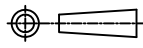

TOLERANCE		DRAWER		 <b>WWW.ASTRON.COM.TW</b>
.0=±0.25		LJF		
.00=±0.15		SRFB		
.000=±0.05		APP'D		NAME USB C TYPE FEMALE HIGH RISE : CH=3.40mm SMT+DIP TYPE
ANG.=±3°		ALAN		
		PRODUCT SPEC.		DRAW NO. 237FC24-XN137T-H
UNITS : mm				
SCALE	SIZE	SHEET	REV.	T0123
NONE	A4	2 OF 3	B	

REV.	DESCRIPTION	DATE
A	RELEASE	Nov. 01, 2019
B	MODIFY	Jan. 04, 2022

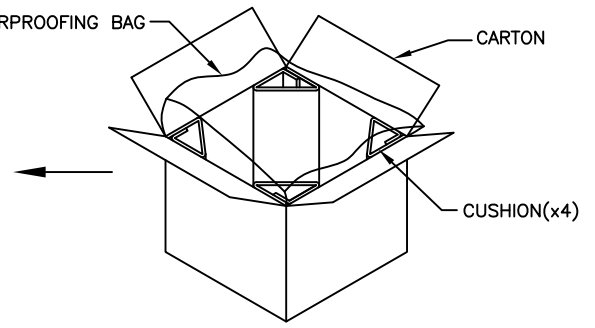
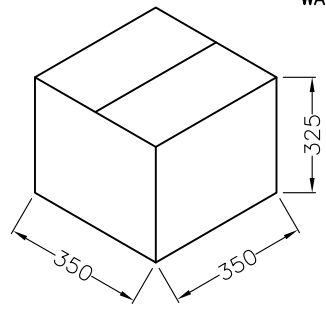
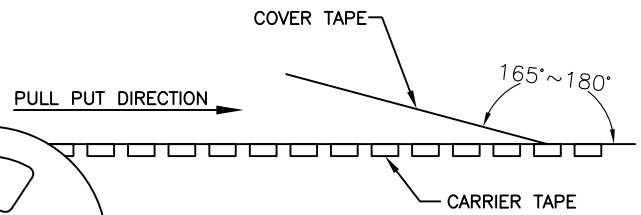
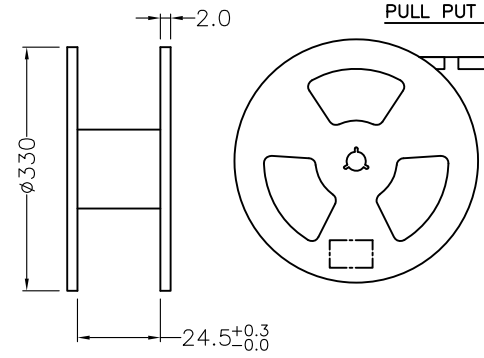
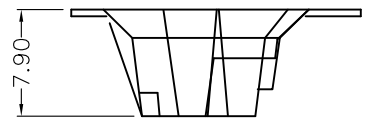
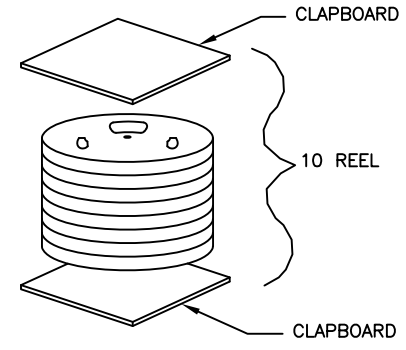
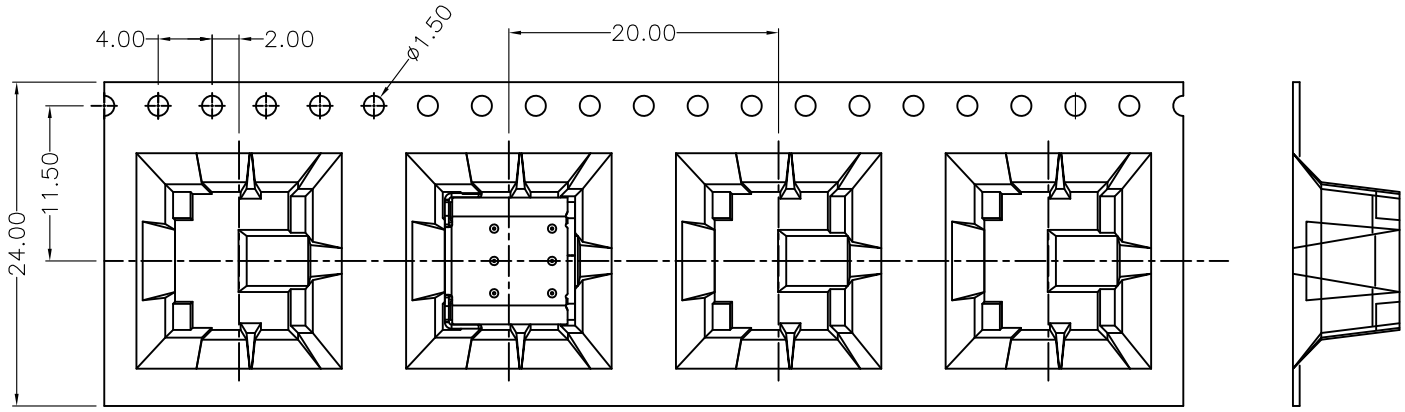
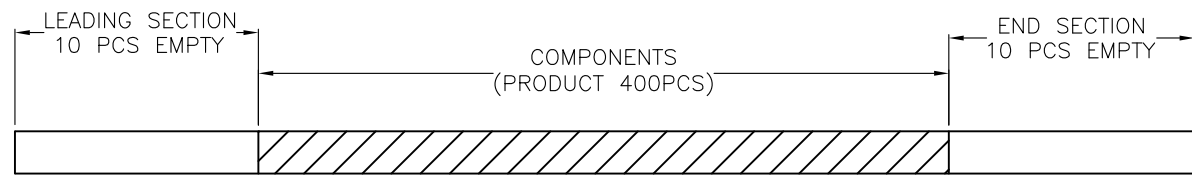

**QUANTITY**  
 1. 400PCS/PER REEL  
 2. 4000 PCS/10 REEL/PER CARTON

<b>TOLERANCE</b>		<b>DRAWER</b>		 <b>WWW.ASTRON.COM.TW</b>
.0=±0.25		LJF		
.00=±0.15		CHECK		
.000=±0.05		SRFB		
ANG.=±3°		APP'D		NAME
 UNITS : mm		ALAN		USB C TYPE FEMALE HIGH RISE : CH=3.40mm SMT+DIP TYPE
		PRODUCT SPEC.		DRAW NO.
SCALE	SIZE	SHEET	REV.	T0123
NONE	A4	3 OF 3	B	237FC24-XN137T-H