

REV.	DESCRIPTION	DATE
A	RELEASE	Oct. 22, 2019
B	MODIFY PACKAGE	Jun. 08, 2020
C	MODIFY DRAW	Jul. 15, 2020
D	ADD DRAW DIM.	Jan. 04, 2021

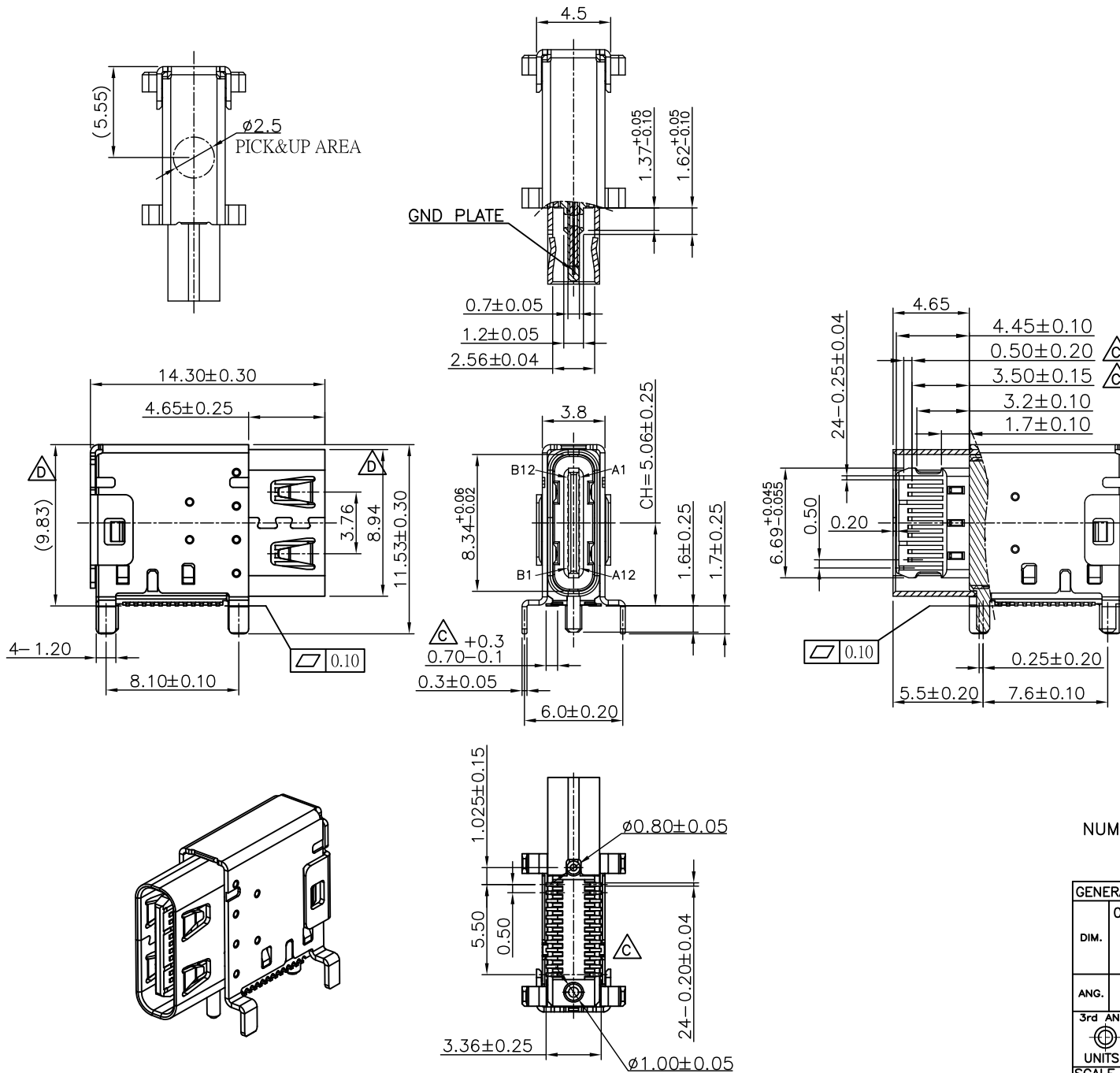

### MATERIALS

- HOUSING : LCP (UL 94V-0), BLACK.
- TERMINAL : COPPER ALLOY,  
GOLD PLATED ON CONTACT AREA,  
GOLD FLASH PLATED ON SOLDER TAIL,  
NICKEL UNDERPLATED OVER ALL.
- MID PLATE : STAINLESS STEEL.
- SHELL : STAINLESS STEEL, NICKEL PLATED.

### SPECIFICATION

- CURRENT RATING : 5.0A FOR Vbus PIN,  
1.25A FOR Vconn PIN,  
0.25A FOR OTHER PINS.
- VOLTAGE RATING : 20V DC MAX.
- CONTACT RESISTANCE : 40mΩ.
- INSULATION RESISTANCE : 100MΩ MIN.
- DIELECTRIC WITHSTANDING VOLTAGE : 100 VAC MIN.
- OPERATING TEMPERATURE : -40°C TO +85°C.
- MATING FORCE : 5~20N.
- UNMATING FORCE : 8~20N.
- DURABILITY : 10,000 CYCLES.
- RECOMMENDED PROCESS :  
THE PEAK TEMPERATURE ON THE BOARD SHALL  
MAINTAIN 260°C.

### PART NUMBER INFORMATION :

239FC24-XN044T-H

SERIES CODE ————  
SMT TYPE ————  
FEMALE ————  
USB TYPE-C ————  
NUMBER OF POSITIONS ————

————— HALOGEN FREE  
————— FOLLOW NUMBER  
————— HOUSING COLOR  
————— CONTACT PLATING OPTION:  
0 : GOLD FLASH  
3 : 15u" GOLD  
6 : 30u" GOLD

GENERAL TOLERANCE		DRAWER		 <b>ASTRON TECHNOLOGY CORP.</b>	
DIM. 0. = ±X.XX		LJF			
.0 = ±0.30		CHECK		NAME	
.00 = ±0.20		ERP			
.000 = ±0.15		APP'D		USB TYPE-C 24PIN FEMALE UPRIGHT TYPE, GEN2	
ANG. .0° = ±3°		ALAN			
.00° = ±1°		PRODUCT SPEC.		PART NO. 239FC24-XN044T-H	
3rd ANGLE PROJECTION		-			
UNITS : mm		<b>CONFIDENTIAL</b>		C NO.	
SCALE NONE	SIZE A4	SHEET 1 OF 3	REV. D	08031(12029)	

REV.	DESCRIPTION	DATE
A	RELEASE	Oct. 22, 2019
B	MODIFY PACKAGE	Jun. 08, 2020
C	MODIFY DRAW	Jul. 15, 2020
D	ADD DRAW DIM.	Jan. 04, 2021

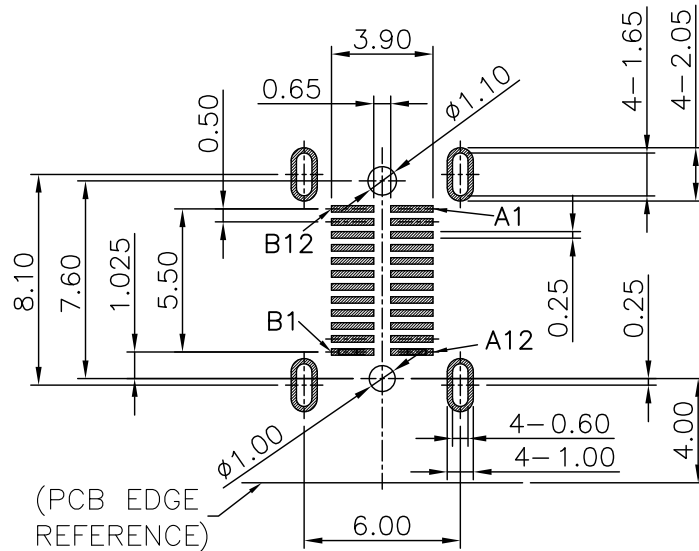
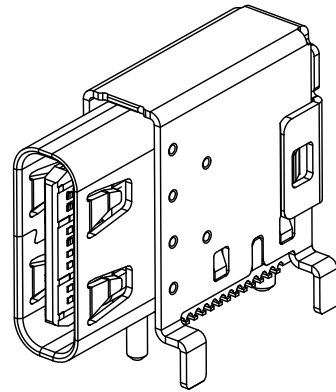

RECOMMENDED P.C.B LAYOUT  
TOLERANCE  $\pm 0.05\text{mm}$  (TOP VIEW)

PIN ASSIGNMENT:

PIN	Signal Name	PIN	Signal Name
A1	GND	B12	GND
A2	SSTXp1	B11	SSRXp1
A3	SSTXn1	B10	SSRXn1
A4	Vbus	B9	Vbus
A5	CC1	B8	SBU2
A6	Dp1	B7	DN2
A7	Dn1	B6	DP2
A8	SBU1	B5	CC2
A9	Vbus	B4	Vbus
A10	SSRXn2	B3	SSTXn2
A11	SSRXp2	B2	SSTXp2
A12	GND	B1	GND

GENERAL TOLERANCE		DRAWER	 <b>ASTRON TECHNOLOGY CORP.</b>
DIM.	0. = $\pm X.XX$ .0 = $\pm 0.30$ .00 = $\pm 0.20$ .000 = $\pm 0.15$	CHECK	
ANG.	.0° = $\pm 5^\circ$ .00° = $\pm 1^\circ$	APP'D	NAME
3rd ANGLE PROJECTION		PACKAGE SPEC.	USB TYPE-C 24PIN FEMALE UPRIGHT TYPE, GEN2
UNITS : mm	SCALE	SIZE	PART NO.
NONE	A4	SHEET	08031(12029)
2 OF 3	REV.	D	C NO.

REV.	DESCRIPTION	DATE
A	RELEASE	Oct. 22, 2019
B	MODIFY PACKAGE	Jun. 08, 2020
C	MODIFY DRAW	Jul. 15, 2020
D	ADD DRAW DIM.	Jan. 04, 2021

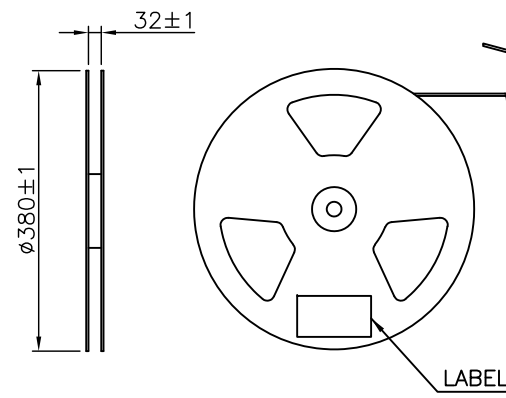
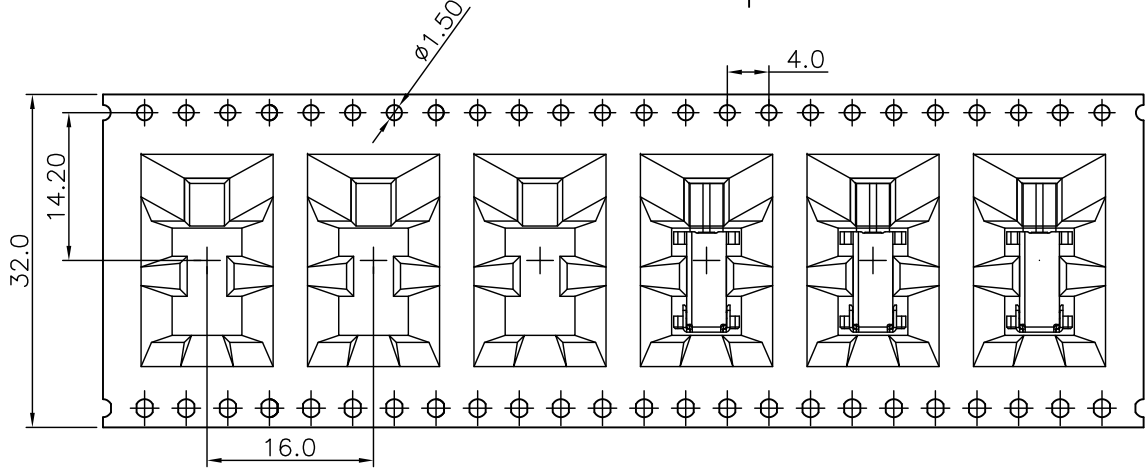
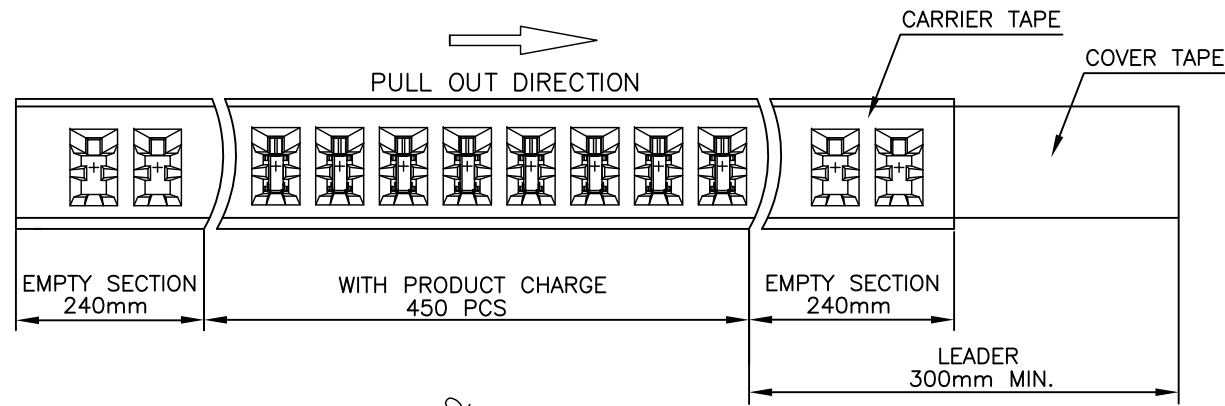

**PACKAGE**

1. SIZE :  
 REEL :  $\phi 380 \times 32$  mm  
 CARTON :  $400 \times 400 \times 300$  mm (LxWxH)
2. QUANTITY :  
 450 PCS / REEL  
 8 REEL / CARTON = 3,600 PCS
3. MATERIAL :  
 CARRIER TAPE : PET, TRANSPARENT.  
 COVER TAPE : PE.

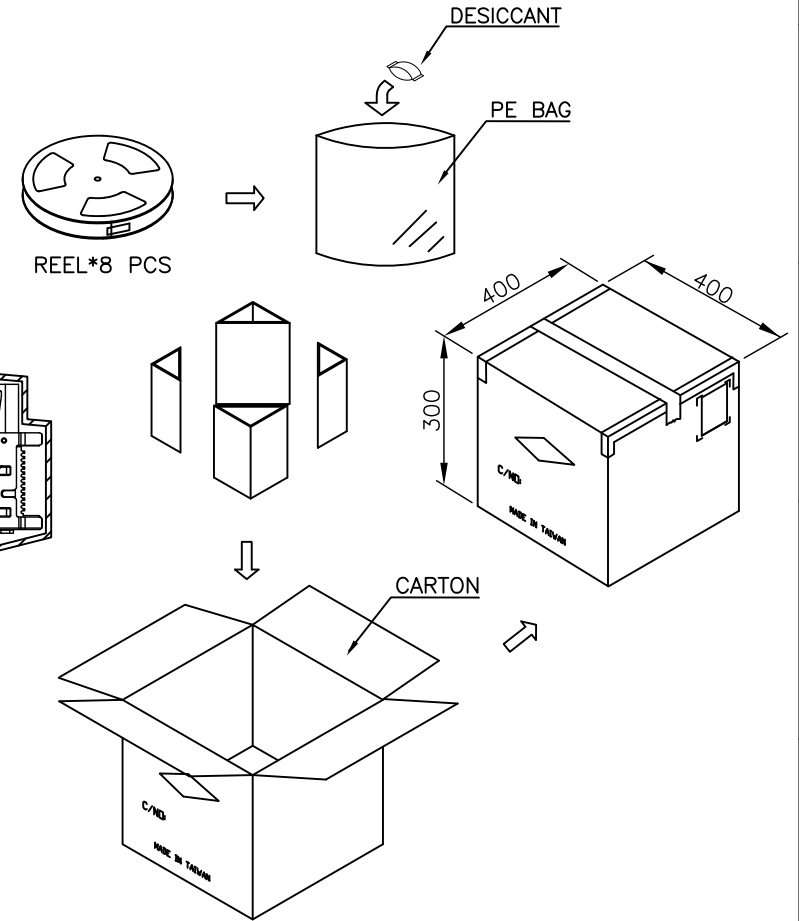

GENERAL TOLERANCE		DRAWER <i>LYJ</i>		 <b>ASTRON TECHNOLOGY CORP.</b>	
DIM. 0. = $\pm X.XX$		CHECK <i>ERP</i>			
.0 = $\pm 0.30$		APP'D <i>ALAN</i>		NAME	
.00 = $\pm 0.20$		PACKAGE SPEC. -		USB TYPE-C 24PIN FEMALE UPRIGHT TYPE, GEN2	
.000 = $\pm 0.15$		3rd ANGLE PROJECTION		PART NO. 239FC24-XN044T-H	
ANG. .0° = $\pm 3'$		UNITS : mm		CONFIDENTIAL	
.00° = $\pm 1'$		SCALE NONE		SHEET 3 OF 3	
		SIZE A4		REV. D	
				08031(12029)	
				C NO.	