

| REV. | DESCRIPTION | DATE          |
|------|-------------|---------------|
| 1    | PRELIMINARY | May. 02, 2019 |
|      |             |               |
|      |             |               |

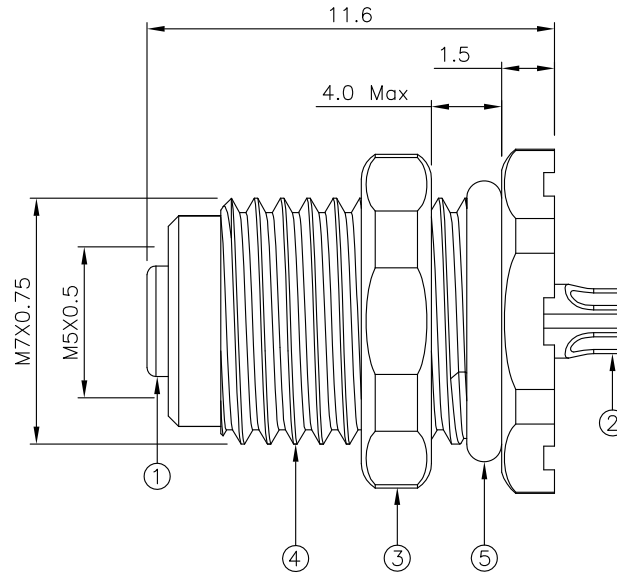
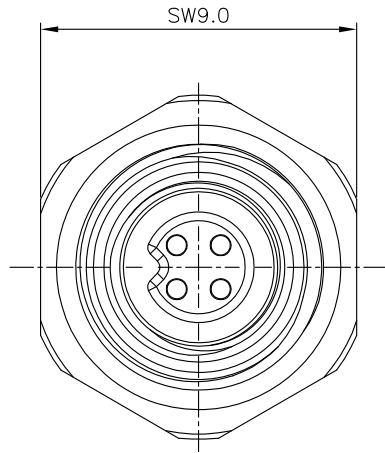

**MATERIALS**

1. HOUSING : NYLON 66 (UL 94V-0), BLACK.
2. TERMINAL : BRASS, GOLD PLATED.
3. SCREW : BRASS, NICKEL PLATED.
4. SHELL : BRASS, NICKEL PLATED.
5. O-RING : RUBBER.

**SPECIFICATION**

1. CURRENT RATING : 1A.
2. VOLTAGE RATING : 60V.
3. CONTACT RESISTANCE : 10mΩ MAX.
4. INSULATION RESISTANCE : 100MΩ Min.
5. WITHSTANDING VOLTAGE : 500V AC/MINUTE.
6. OPERATING TEMPERATURE : -20°C TO +80°C.
7. DURABILITY : 500 CYCLES.
8. WATERPROOF : IP67.

Pin Assignments Front View

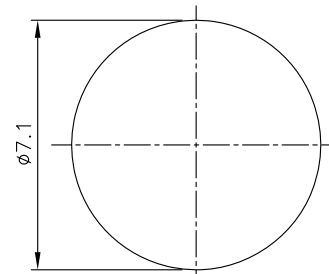
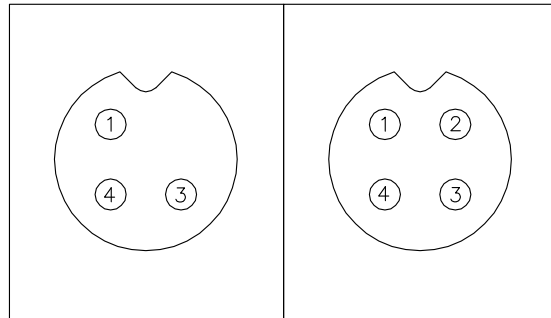

Recommended Panel Cut-Out

**PART NUMBER INFORMATION :**

301P8XX-ON016T-R

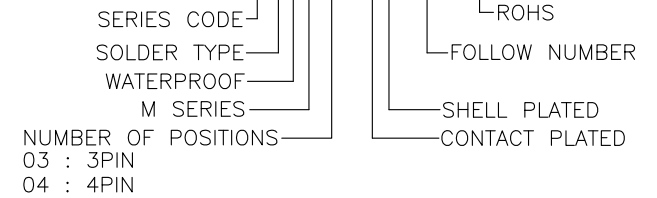

|                      |   |                     |        |   |  |
|----------------------|---|---------------------|--------|---|--|
| GENERAL TOLERANCE    |   | DRAWER <i>KENNY</i> |        | <br><b>ASTRON TECHNOLOGY CORP.</b>                    |  |
| DIM.                 | 0. = ±X.XX<br>.0 = ±0.20<br>.00 = ±0.10<br>.000 = ±X.XX | CHECK <i>JOE</i>    |        |   |  |
| ANG.                 | .0° = ±3°<br>.00° = ±1°                                 | APP'D <i>ALAN</i>   |        | NAME<br>M5 A CODE SOCKET<br>STRAIGHT TYPE, WATERPROOF |  |
| 3rd ANGLE PROJECTION |   | PRODUCT SPEC. -     |        | PART NO. 301P8XX-ON016T-R                             |  |
| UNITS : mm           |   | <b>CONFIDENTIAL</b> |        | 20001   |  |
| SCALE NONE           | SIZE A4   | SHEET 1 OF 1        | REV. 1 | C NO.   |  |