

REV.	DESCRIPTION	DATE
A	N16'10001	Oct.11, 2016
B	ADD P/N	Mar.07, 2018

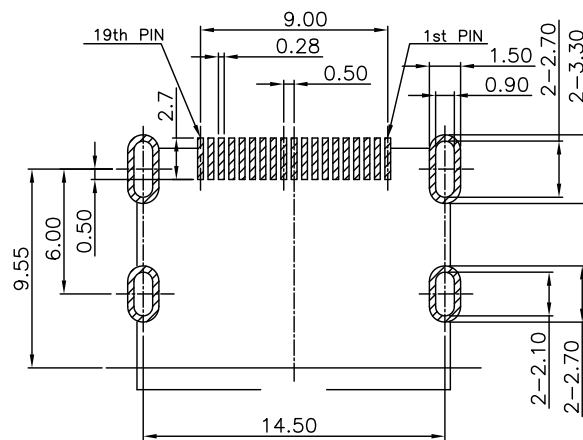
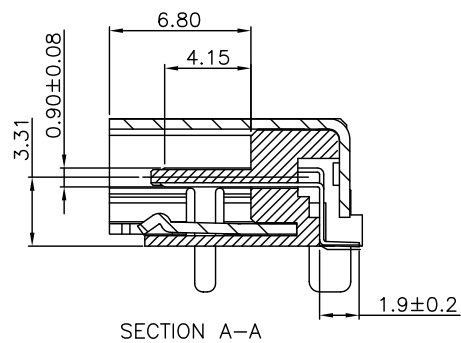
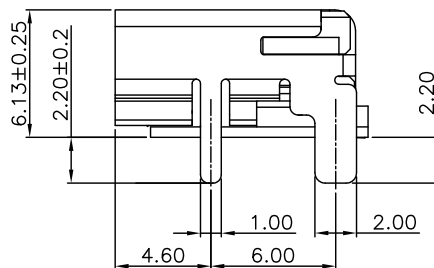
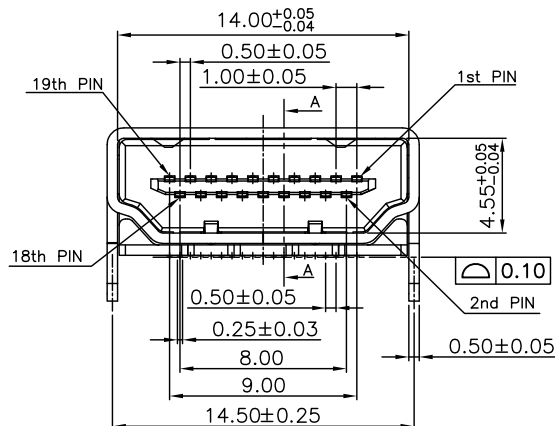
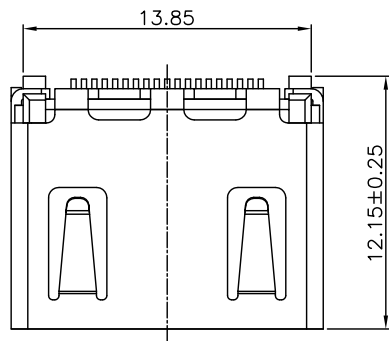

RECOMMEND PCB LAYOUT
TOLERANCE: ±0.05
TOP VIEW

MATERIALS

- HOUSING : HI.-TEMP.PLASTIC(UL 94V-0), BLACK.
- TERMINAL : COPPER ALLOY,
PLATING : GOLD PLATED ON CONTACT AREA,
100u" TIN PLATED ON SOLDER TAILS.
- SHELL : COPPER ALLOY,
PLATING : 100u" NICKEL PLATED OVERALL.

SPECIFICATION

- CURRENT RATING : 0.5 A. MAX.
- DIELECTRIC WITHSTANDING VOLTAGE :
500V AC R.M.S. FOR 1 MINUTE.
- INSULATION RESISTANCE : 100MΩ MIN.AT 500V DC.
- CONTACT RESISTANCE : 30mΩ MAX.
- OPERATING TEMPERATURE : -25°C TO +85°C.
- INSERTION FORCE : 4.5Kgf MAX.
- WITHDRAWING FORCE : 1Kgf ~ 4Kgf.

PART NUMBER INFORMATION :

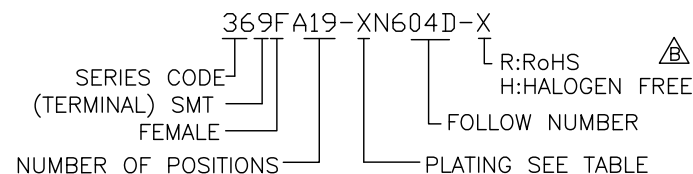

DESCRIPTION OF PLATING ON TERMINALS			
NO.	EXPLAIN	NO.	EXPLAIN
0	GOLD FLASH	3	GOLD 15u"
6	GOLD 30u"		

TOLERANCE .0=±0.25 .00=±0.15 .000=±0.05 ANG.=±3°	DRAWER <i>Chen</i> CHECK <i>Flony</i> APP'D <i>Flony</i>	 Astron ASTRON TECHNOLOGY CORP. NAME HDMI FEMALE A TYPE DRAW NO. R369FA19-XN604D-X
UNITS : mm	PRODUCT SPEC.	
SCALE NONE	SIZE A7	
SHEET 1 OF 2	REV. B	

REV.	DESCRIPTION	DATE
A	N16'10001	Oct.11, 2016
B	ADD P/N	Mar.07, 2018

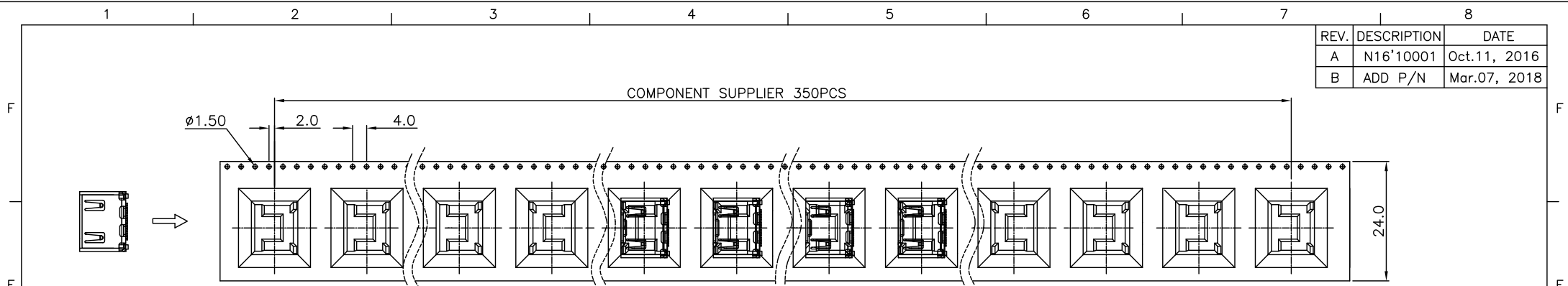

PULL OUT DIRECTION

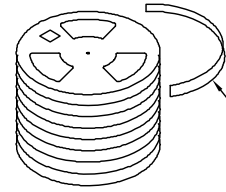
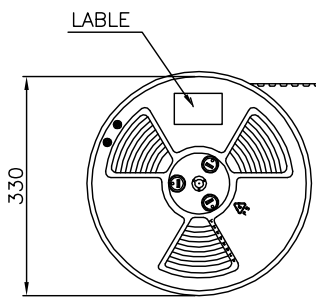

PROTECTOR TAPE

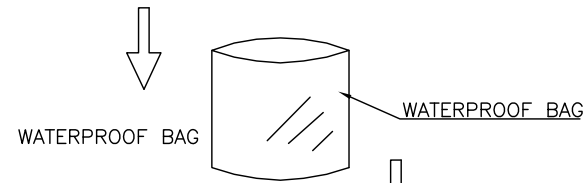

WATERPROOF BAG

WATERPROOF BAG

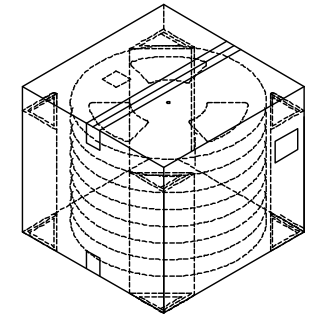
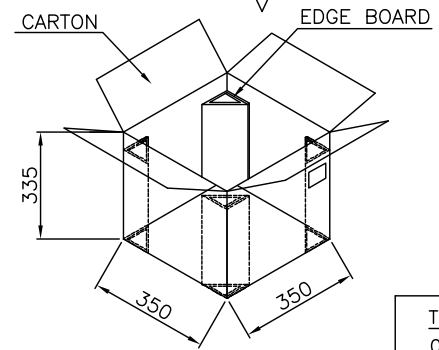

TAPE & REEL PACKAGE:

MATERIALS

- 1.CARRIER TAPE: PS
- 2.COVER TAPE: PET
- 3.REEL: PS

QUANTITY

- 1.350PCS PER REEL
- 2.3500PCS PER CARTON

TOLERANCE		DRAWER		Astron ASTRON TECHNOLOGY CORP.
.0=±0.25		CHECK		
.00=±0.15		APP'D		
.000=±0.05		PRODUCT SPEC.		NAME
ANG.=±3°		UNITS : mm		HDMI FEMALE A TYPE
SCALE NONE		SIZE A7		DRAW NO.
SHEET 2 OF 2		REV. B		R369FA19-XN604D-X