

REV.	DESCRIPTION	DATE
A	RELEASED	Sep. 09, 2020

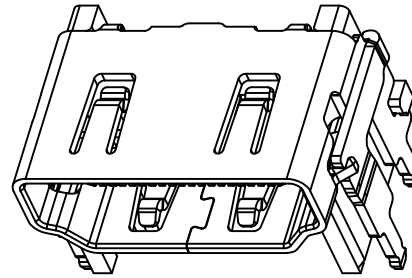
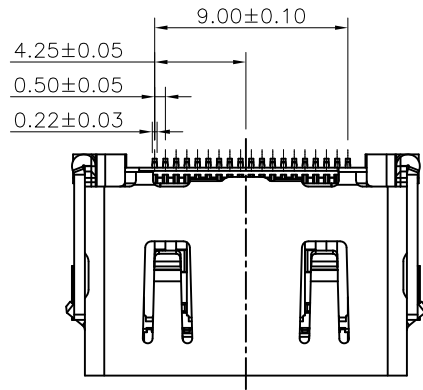

3D VIEW

**MATERIALS**

- HOUSING : LCP (UL 94V-0), BLACK.
- TERMINAL : BRASS, GOLD PLATED ON CONTACT AREA, GOLD FLASH PLATED ON SOLDER TAILS, NICKEL UNDERPLATING.
- SHELL : STAINLESS STEEL, NICKEL PLATED.

**SPECIFICATION**

- CURRENT RATING : 0.5A MIN.
- VOLTAGE RATING : 40V AC.
- CONTACT RESISTANCE : 10mΩ MAX.
- INSULATION RESISTANCE : 100MΩ MIN.
- DIELECTRIC WITHSTANDING VOLTAGE : 500V AC.
- OPERATING TEMPERATURE : -25°C TO +85°C.
- MATING FORCE : 44.1N MAX.
- UNMATING FORCE : 9.8N MIN.

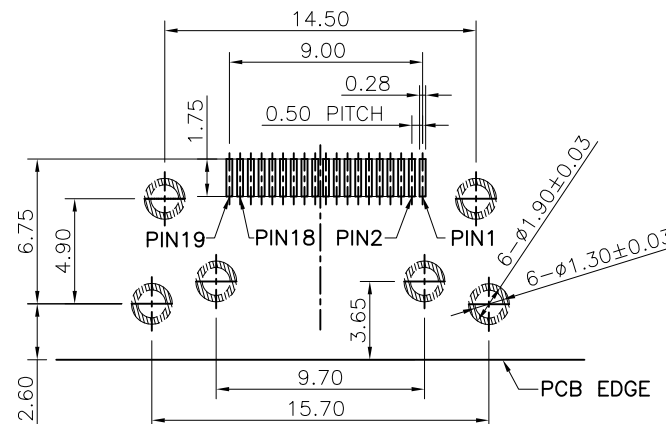
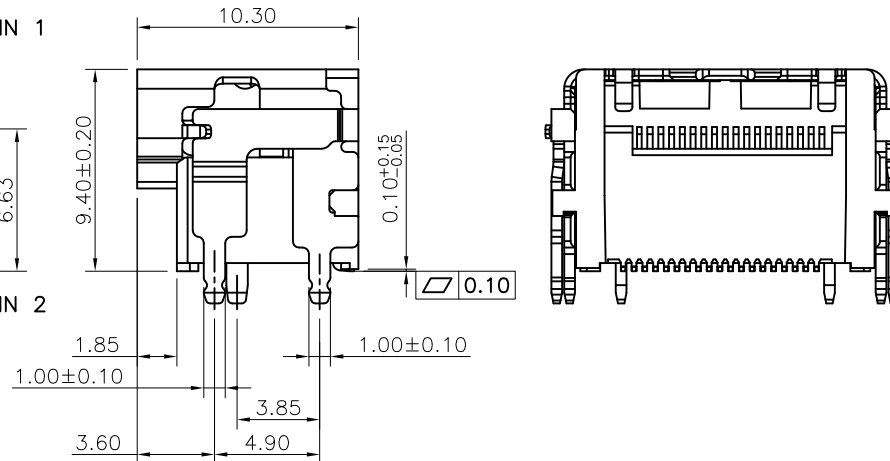
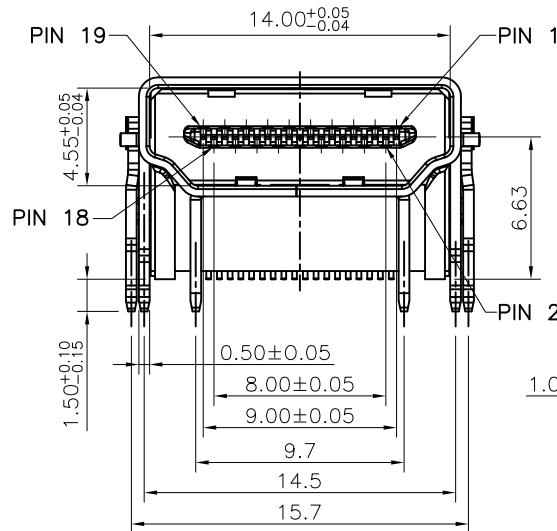

RECOMMEND PCB LAYOUT  
TOLERANCE: ±0.05(TOP VIEW)

**PART NUMBER INFORMATION :**

369FA19-XN654T-H

- SERIES CODE
- SMT TYPE
- FEMALE
- TYPE-A
- NUMBER OF POSITIONS
- HALOGEN FREE
- FOLLOW NUMBER
- SHELL PLATED
- CONTACT PLATED
- 0 : GOLD FLASH
- 6 : 30u" GOLD

GENERAL TOLERANCE		DRAWER	DRAWER	
DIM.	0. = ±0.35 .0 = ±0.25 .00 = ±0.20	CHECK	APP'D	
ANG.	0.° = ±1° .0° = ±0.5° .00° = ±X.X°	PRODUCT SPEC.	NAME	
3rd ANGLE PROJECTION		CONFIDENTIAL		PART NO.
SCALE	SIZE	SHEET	REV.	C NO.
NONE	A4	1 OF 2	A	14026

**Astron®**  
**ASTRON TECHNOLOGY CORP.**

NAME  
HDMI 2.1 TYPE-A FEMALE  
SMT TYPE , HIGH RISE TYPE

PART NO. 369FA19-XN654T-H

REV.	DESCRIPTION	DATE
A	RELEASED	Sep. 09, 2020

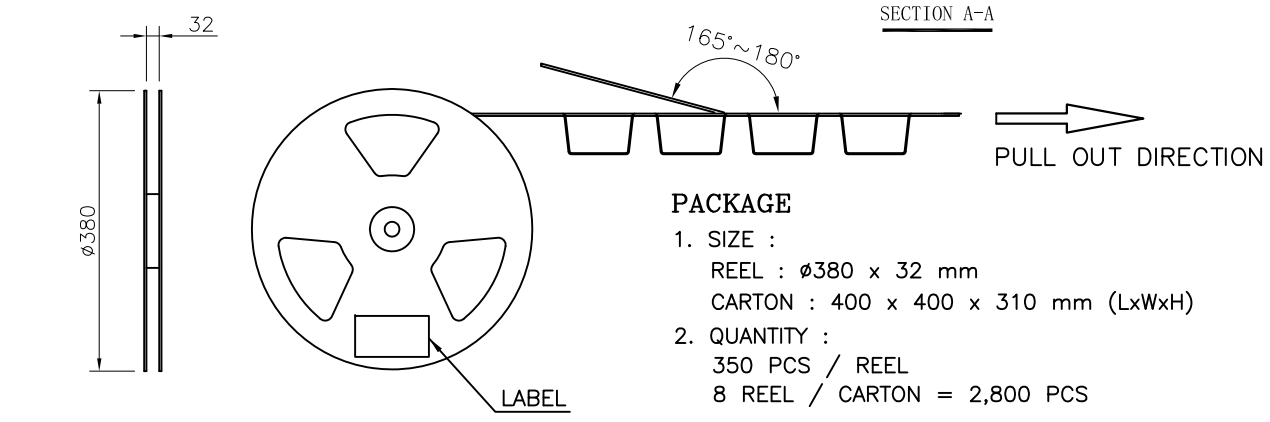
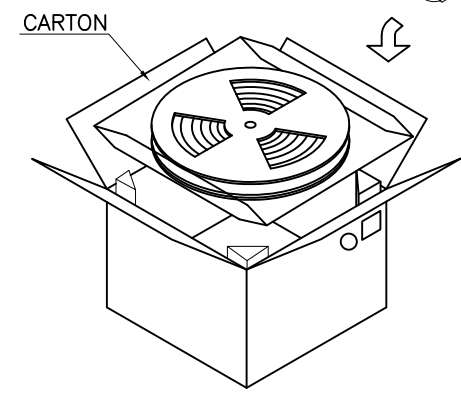
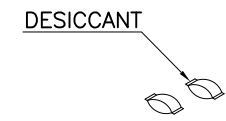
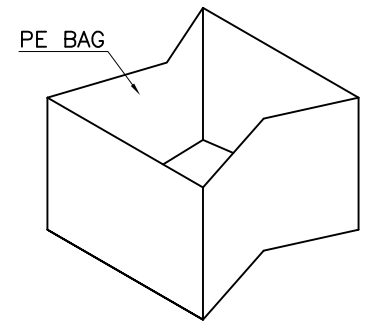
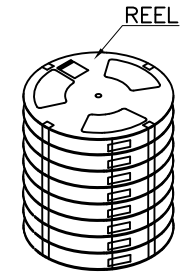
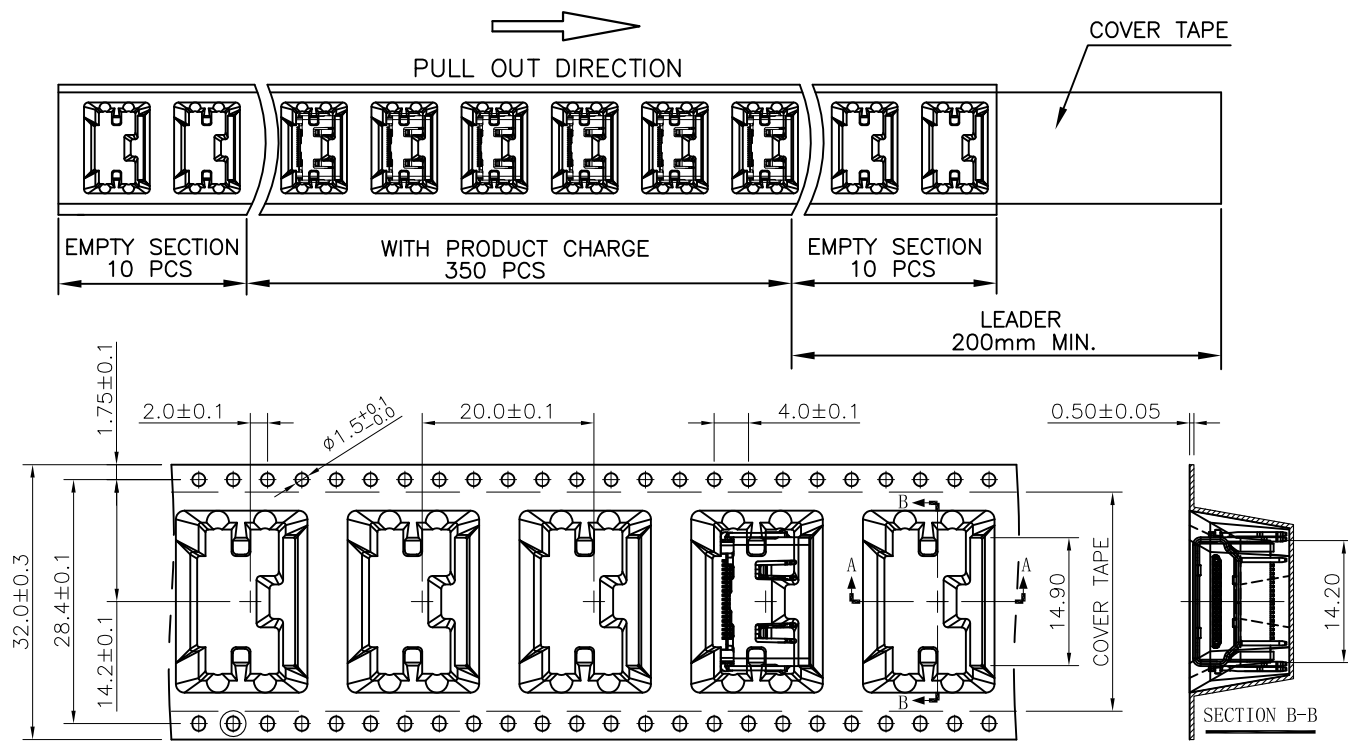

**PACKAGE**

1. SIZE :  
 REEL :  $\phi 380 \times 32$  mm  
 CARTON :  $400 \times 400 \times 310$  mm (LxWxH)
2. QUANTITY :  
 350 PCS / REEL  
 8 REEL / CARTON = 2,800 PCS

GENERAL TOLERANCE	DRAWER	 <b>ASTRON TECHNOLOGY CORP.</b>			
DIM.	CHECK				
ANG.	APP'D				
3rd ANGLE PROJECTION	PACKAGE SPEC.	NAME			
SCALE	SIZE	SHEET	REV.	PART NO.	
NONE	A4	2 OF 2	A	369FA19-XN654T-H	
				14026	C NO.