

REV.	DESCRIPTION	DATE
A	RELEASE	Jul. 03, 2017

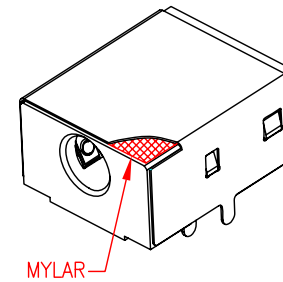
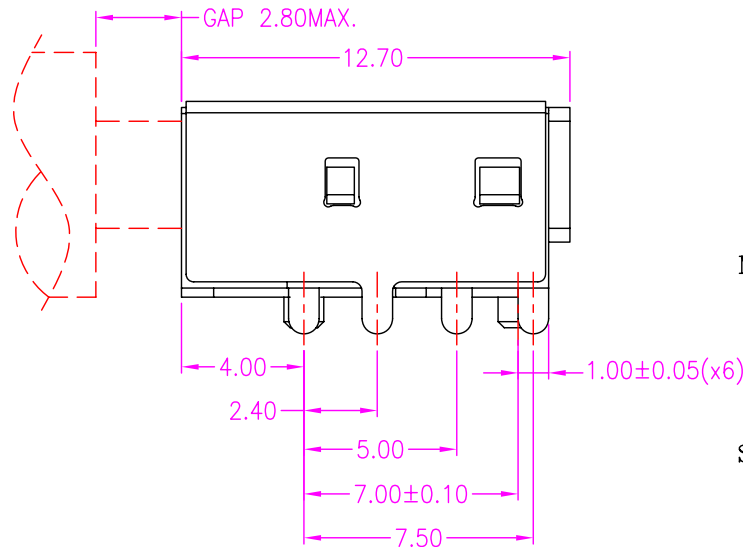
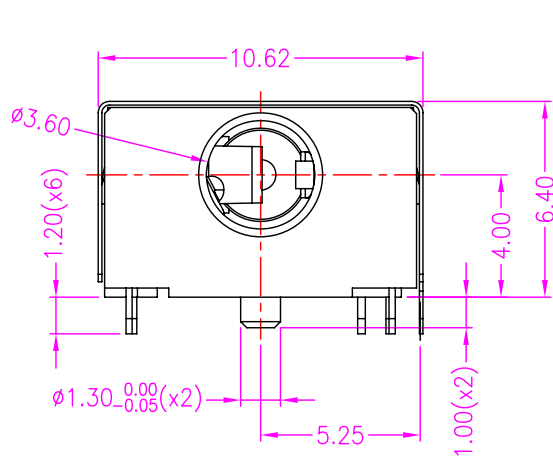

### MATERIALS

- HOUSING : NYLON 4T, (UL 94V-0), BLACK.
- TERMINAL : PHOSPHOR BRONZE, GOLD FLASH PLATING.  
PIN1,4,5: (t=0.20mm); PIN3: (t=0.30mm)  
PIN2: (t=0.25mm)
- SHELL(GND) : STAINLESS STEEL(t=0.15mm), NICKEL PLATING.

### SPECIFICATION

- CURRENT RATING : 1 AMP. MAX.
- RATING VOLTAGE : 12V DC
- DIELECTRIC WITHSTANDING VOITAGE :  
500V AC R.M.S. FOR ONE MINUTE.
- INSULATION RESISTANCE : 100M OHMS MIN. AT 500V DC.
- CONTACT RESISTANCE : 50m OHMS MAX.
- MATING FORCE : 0.3~3.0 Kgf
- UMMATING FORCE : 0.3~3.0 Kgf
- DURABILITY : 5,000 CYCLES
- OPERATING TEMPERATURE: -25°C. TO +85°C.
- RESISTANCE TO SOLDER HEAT : 260°C/5sec min.

### PART NUMBER INFORMATION

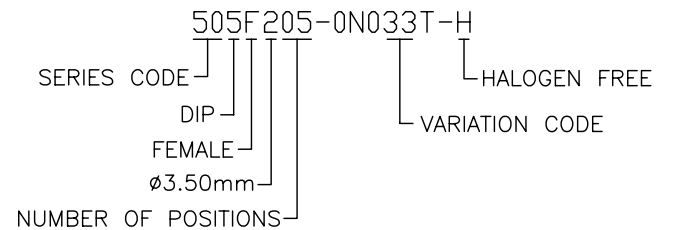

TOLERANCE		DRAWER		 <b>WWW.ASTRON.COM.TW</b>
.0=±0.30		JINJ		
.00=±0.20		CHECK		
.000=±		APP'D		NAME
.0000=±.		ERJB		
ANG.=±3°		PRODUCT SPEC.		DIP TYPE
UNITS : mm		DRAW NO.		505F205-0N033T-H
SCALE	SIZE	SHEET	REV.	T0120
NONE	A4	1 OF 2	A	

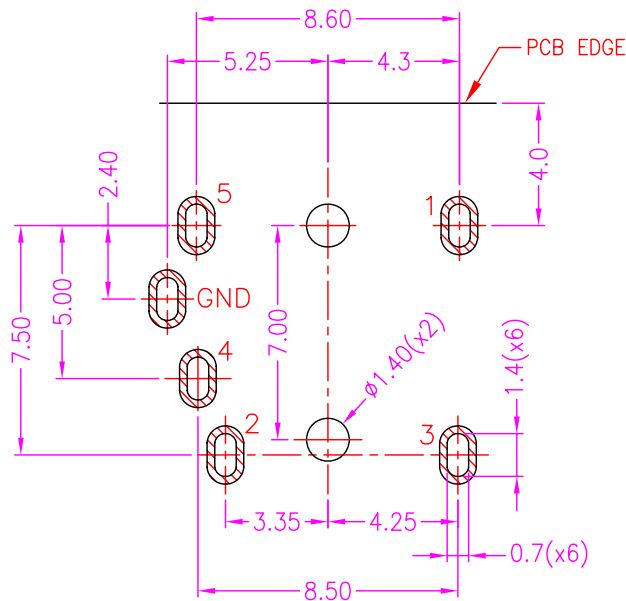
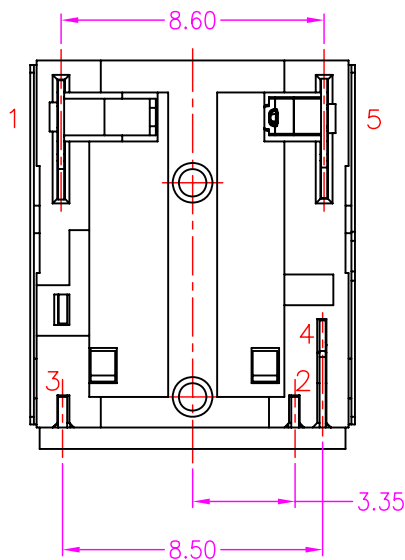

RECOMMEND P.C.B. LAYOUT  
TOP VIEW

### SCHEMATIC

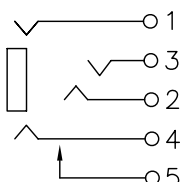

REV.	DESCRIPTION	DATE
A	RELEASE	Jan. 03, 2017

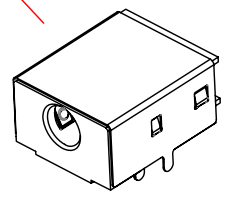
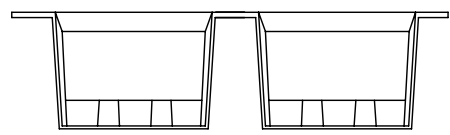
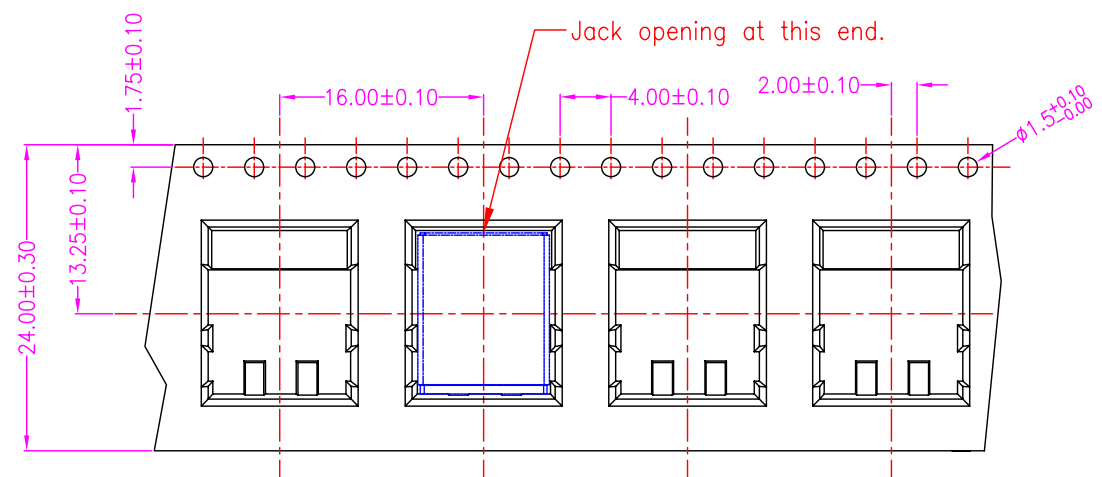
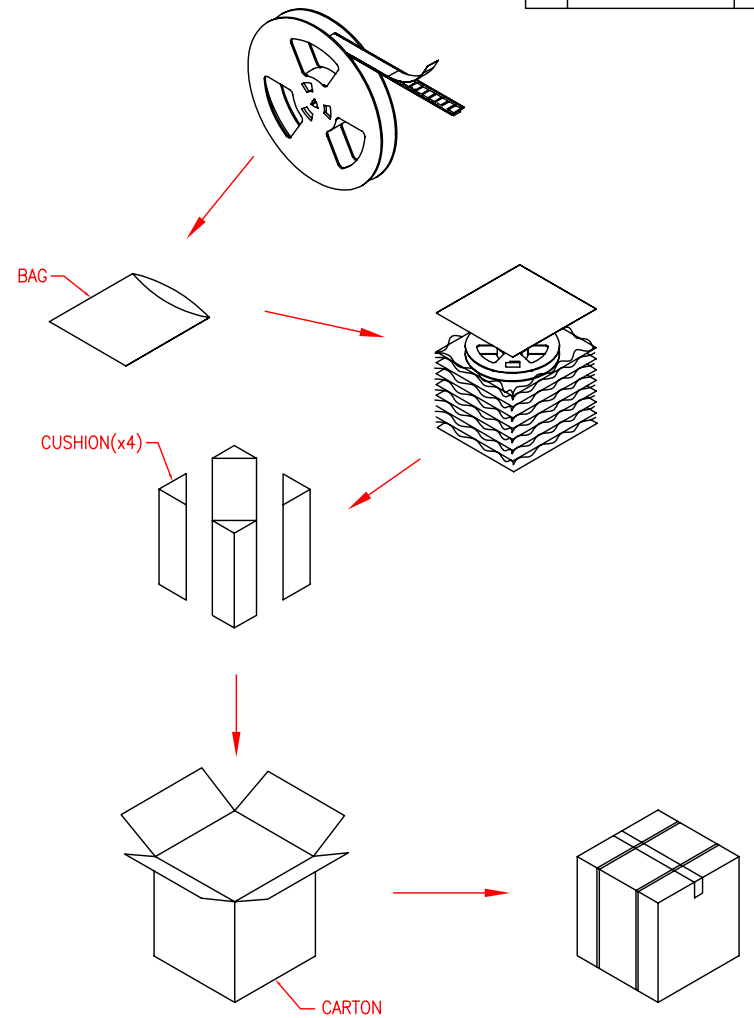
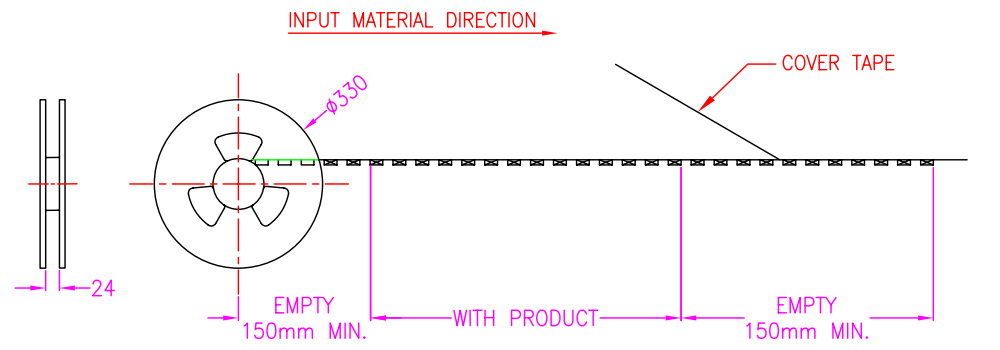

- PACKAGE :
- 500PCS PER REEL
  - 6000PCS /12 REEL / PER CARTON
  - CARTON DIM : 350(L)X350(W)X385(H)

TOLERANCE		DRAWER		 <b>Astron</b> <a href="http://WWW.ASTRON.COM.TW">WWW.ASTRON.COM.TW</a>
.0=±		JIN		
.00=±		CHECK		
.000=±		APP'D		NAME
.0000=±.		ERFB		ø3.50mm EARPHONE JACK
ANG.=±3°		PRODUCT SPEC.		DIP TYPE
 UNITS : mm		DRAW NO.		505F205-0N033T-H
SCALE	SIZE	SHEET	REV.	T0120
NONE	A4	2 OF 2	A	