

| REV. | DESCRIPTION | DATE          |
|------|-------------|---------------|
| A    | RELEASE     | Jan. 16, 2019 |
|      |             |               |

### MATERIALS

- HOUSING : HIGH-TEMP PLASTIC, (UL 94V-0), BLACK.
- TERMINAL : COPPER ALLOY, GOLD FLASH PLATING OVER NICKEL.  
PIN 1,2,4 : (t=0.20mm)  
PIN 5 : (t=0.30mm)  
PIN 6 : (t=0.25mm)
- TERMINAL : (PIN 3) COPPER ALLOY (t=0.30mm), NICKEL PLATING.
- DRIVE IC : TX

### SPECIFICATION

- CURRENT RATING : 0.5 AMP.
- RATING VOLTAGE : 30V DC.
- DIELECTRIC WITHSTANDING VOLTAGE :  
500V AC R.M.S. FOR ONE MINUTE.
- INSULATION RESISTANCE : 100M OHMS MIN.  
AT 500V DC.
- CONTACT RESISTANCE : 50m OHMS MAX.
- OPERATING TEMPERATURE : -25°C TO +70°C
- DURABILITY : 5,000 CYCLES.
- MATING FORCE : 0.3~3.0 kgf
- UNMATING FORCE : 0.3~3.0 kgf

### PART NUMBER INFORMATION

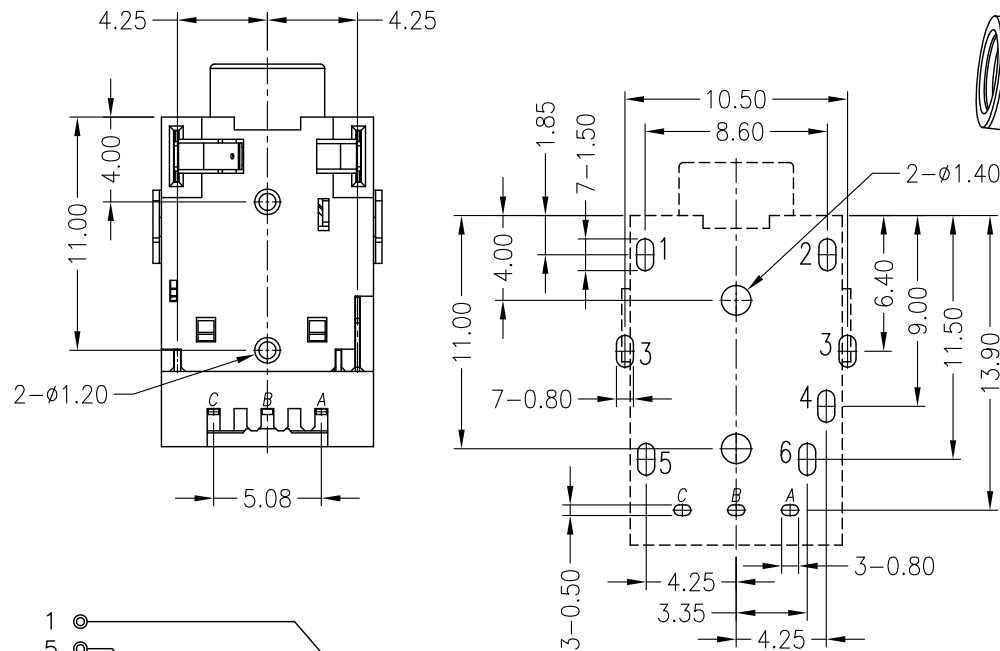
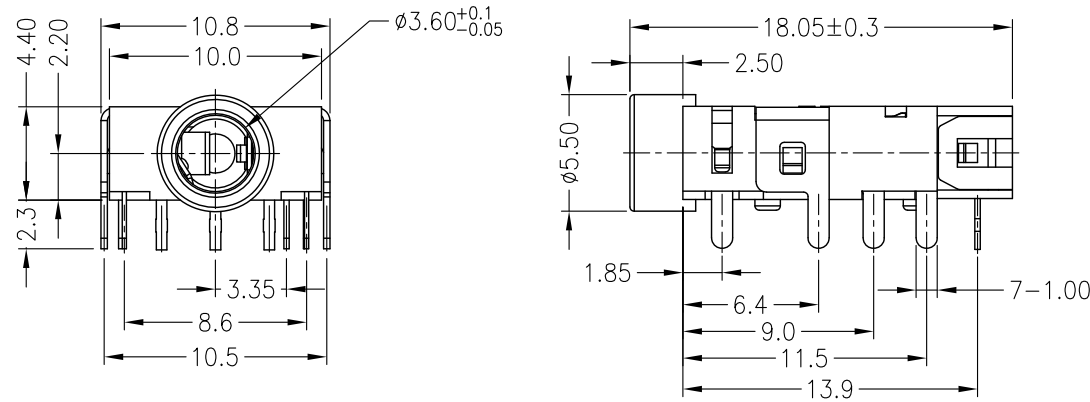
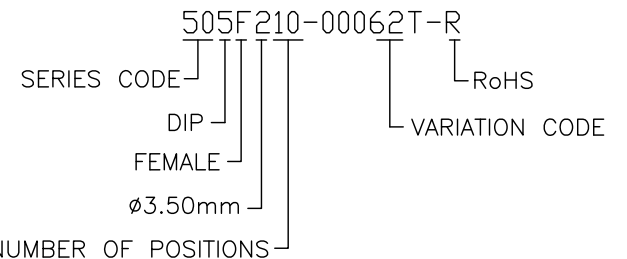

RECOMMEND P.C.B. LAYOUT  
BOTTOM VIEW

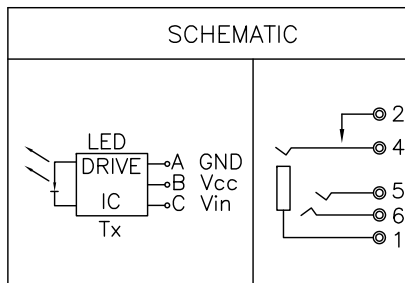
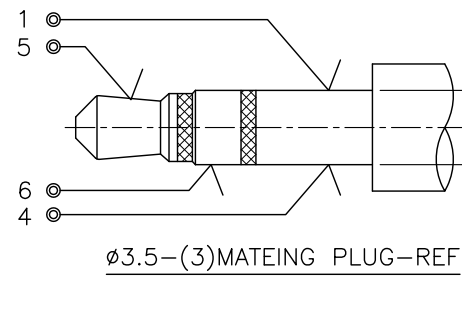

| TOLERANCE  |           | DRAWER  |              | NAME             |
|------------|-----------|---------|--------------|------------------|
| .0=±0.30   | .00=±0.25 | ERP     | JOE          |                  |
| .000=±     | ANG.=±3'  | APP'D   | ALAN         | PRODUCT SPEC.    |
| UNITS : mm |           | SCALE   |              | DRAW NO.         |
| SCALE NONE |           | SIZE A4 | SHEET 1 OF 2 | 505F210-00062T-R |
| REV. A     |           | REV. A  |              | 08026            |

| REV. | DESCRIPTION | DATE          |
|------|-------------|---------------|
| A    | RELEASE     | Jan. 16, 2019 |

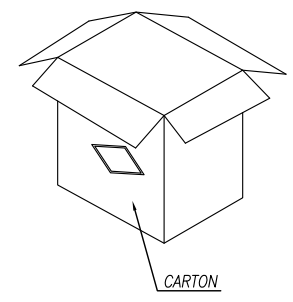
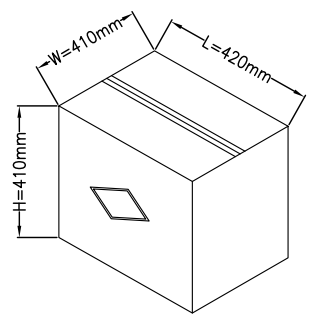
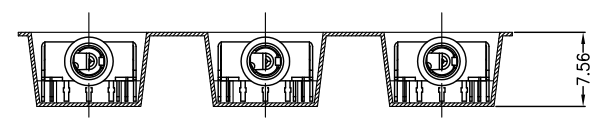
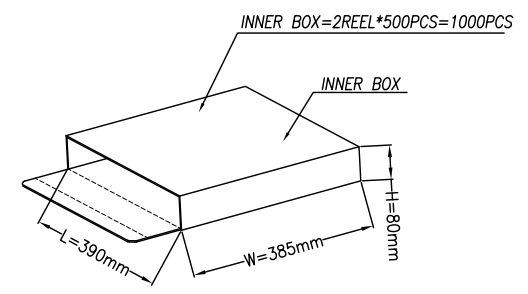
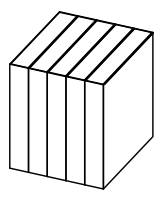
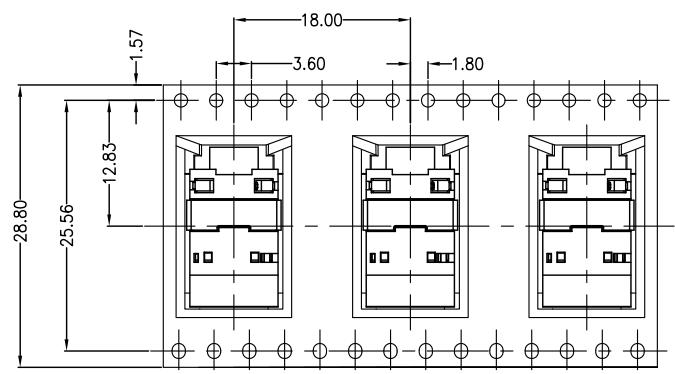
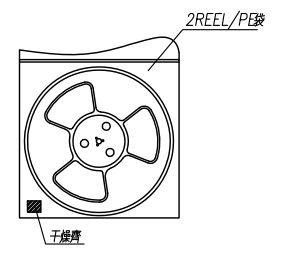
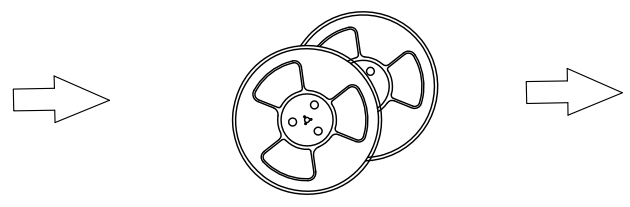
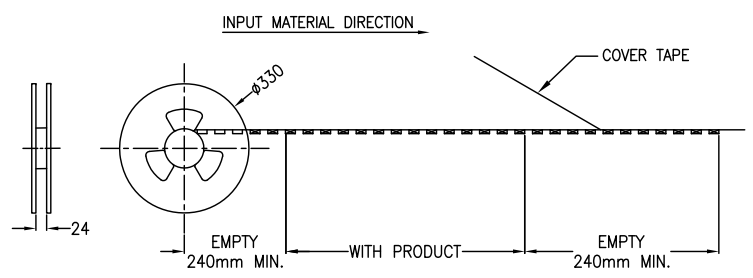

**PACKAGE :**

- 500PCS PER REEL
- 5000PCS /10 REEL / PER CARTON
- CARTON DIM : 420(L)X410(W)X410(H)

|            |      |               |      |   |
|------------|------|---------------|------|---|
| TOLERANCE  |      | DRAWER        |      | <br><b>Astron</b><br><b>WWW.ASTRON.COM.TW</b> |
| .0=±       |      | ERB           |      |   |
| .00=±      |      | CHECK         |      |   |
| .000=±     |      | JOE           |      | NAME  |
| .0000=±    |      | APP'D         |      |   |
| ANG.=±3°   |      | ALAN          |      | DIP TYPE                                      |
|            |      | PRODUCT SPEC. |      | DRAW NO.                                      |
| UNITS : mm |      | —             |      |   |
| SCALE      | SIZE | SHEET         | REV. | T0120   |
| NONE       | A4   | 2 OF 2        | A    |   |