

REV.	DESCRIPTION	DATE
A	RELEASE	Jul. 24, 2013

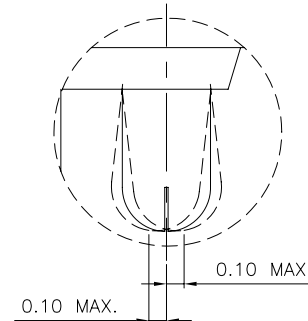
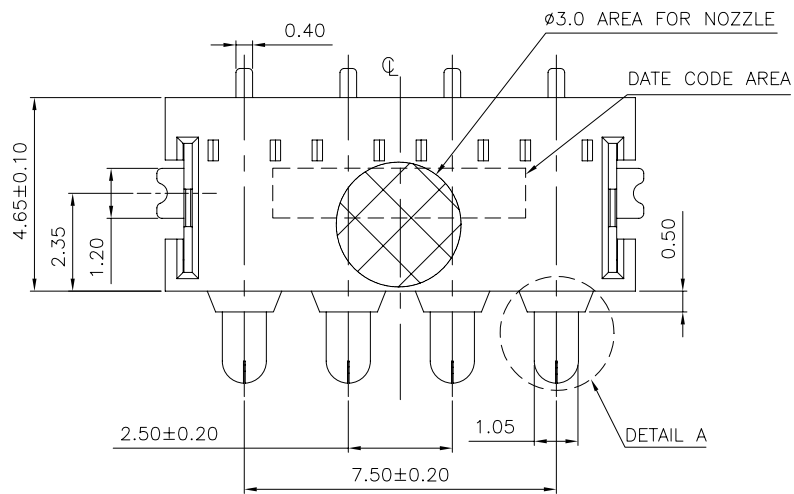

DETAIL A
SCALE 2:1

1. MATERIALS

- 1-1. HOUSING: PA4T (UL 94V-0), BLACK.
- 2-2. FRONT CONTACT: BRASS C2680R-H.
- 3-3. BACK CONTACT: PHOSPHOR BRONZE C5210R-SH.
- 4-4. HOLD DOWN: BRASS C2680R-H.
- 5-5. SPRING: SUS304.

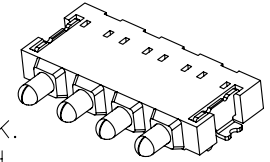

2. FINISH

- 2-1. FRONT CONTACT: GOLD PLATED ON CONTACT AREA NICKEL 50u" MIN. UNDER PLATED.
- 2-2. BACK CONTACT: GOLD 15u" PLATED ON CONTACT AREA G/F PLATED ON SOLDER AREA NICKEL 50u" MIN. UNDER PLATED.
- 2-3. HOLD DOWN: MATTE TIN 80u" MIN. PLATED OVERALL NICKEL 50u" MIN. UNDER PLATED.

3. SPECIFICATION

- 3-1. CURRENT RATING : 4 A MAX.
- 3-2. DURABILITY : 10000 CYCLES.
- 3-3. NORMAL FORCE : 150±30g@1.0mm

4. PART NUMBER INFORMATION

6593304-X0001T-H

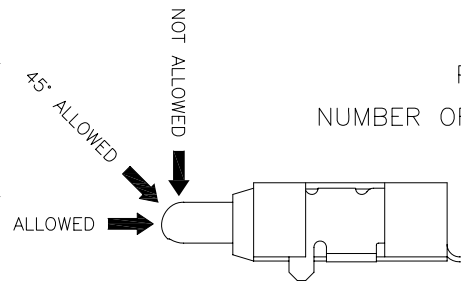
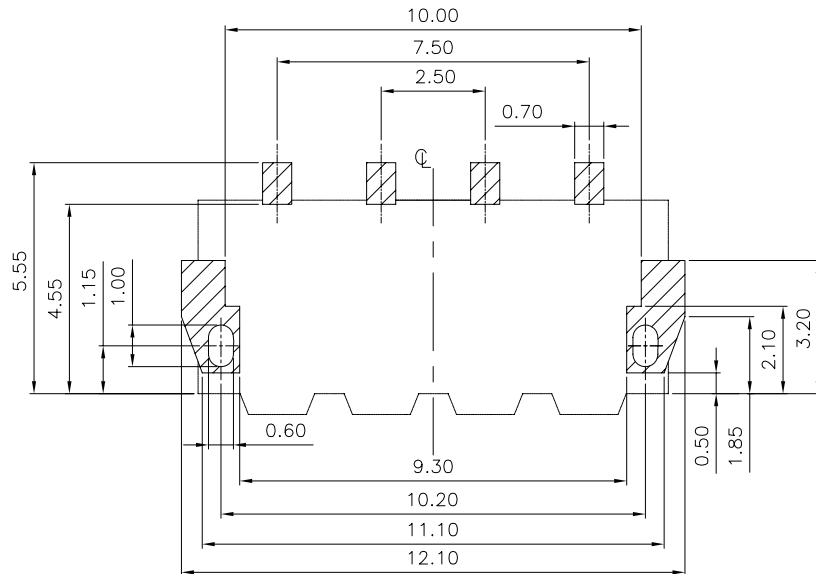
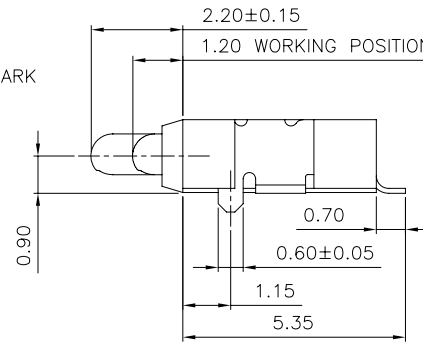
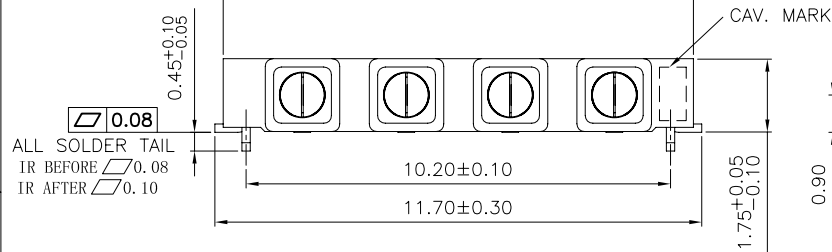
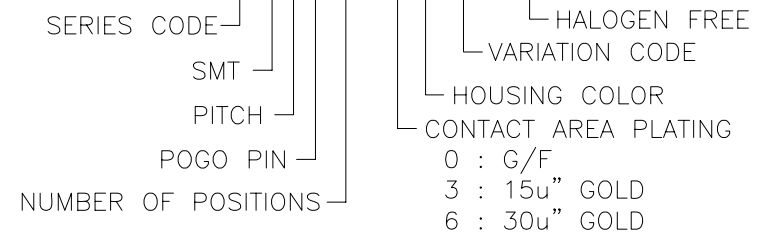

RECOMMENDED BATTERY PACK INSERTION ANGLE

TOLERANCE .0=±0.25 .00=±0.15 .000=±0.05 ANG.=±3°	DRAWER <i>BJN</i>	 ASTRON TECHNOLOGY CORP. NAME 4 PINS BATTERY CONNECTOR H=1.75mm
UNITS : mm	CHECK	
SCALE NONE	SIZE A7	DRAW NO. R6593304-X0001T-H
SHEET 1 OF 2	REV. A	PRODUCT SPEC.

REV.	DESCRIPTION	DATE
A	RELEASE	Jul. 24, 2013

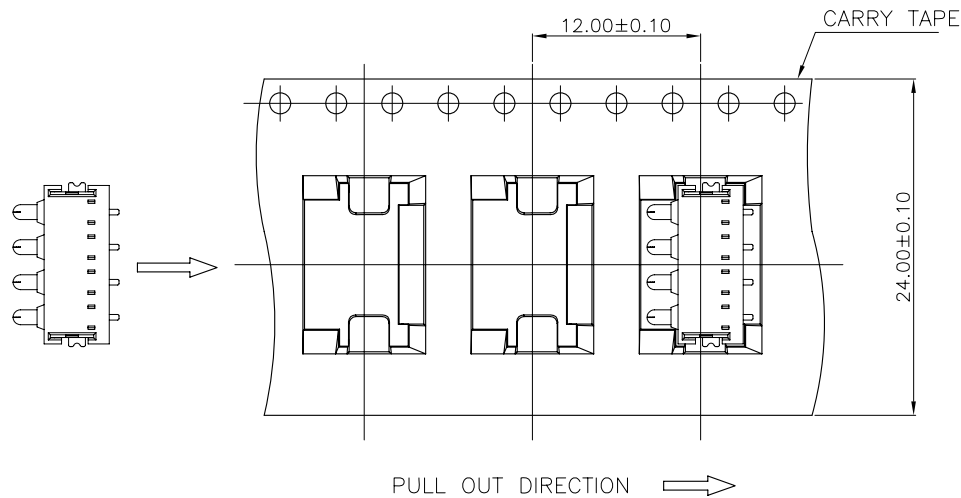
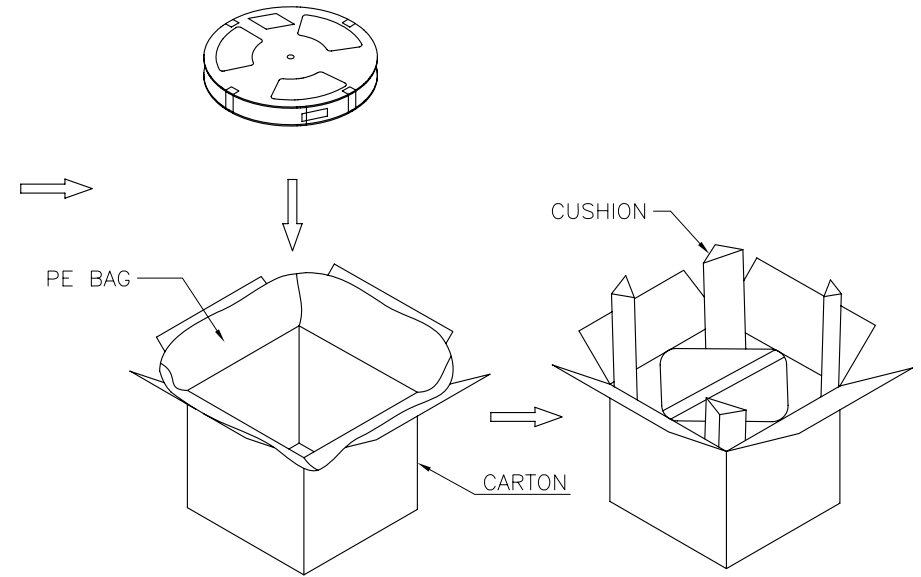
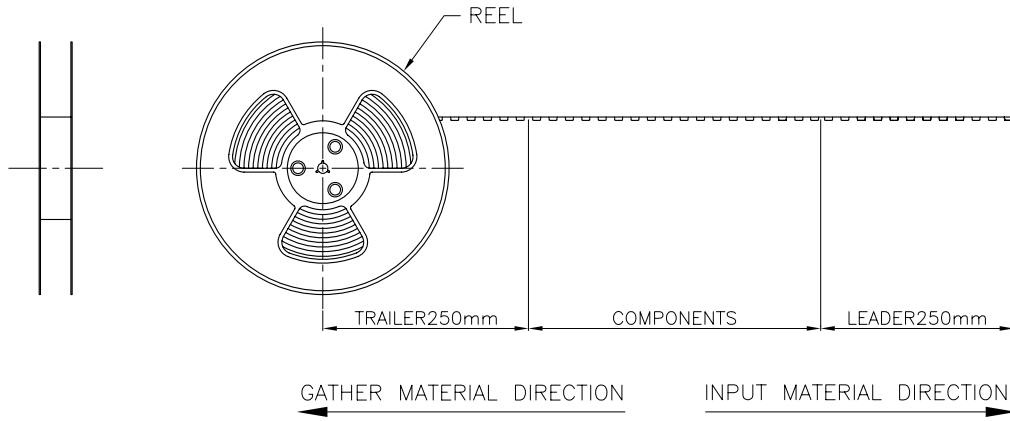

PACKAGE

- 1. QUANTITY :
1500 PCS/REEL
6 REEL/CARTON = 9000PCS

TOLERANCE .0=±0.25 .00=±0.15 .000=±0.05 ANG.=±3°	DRAWER	 ASTRON TECHNOLOGY CORP.
	CHECK	
 UNITS : mm	APP'D	4 PINS BATTERY CONNECTOR H=1.75mm
	PRODUCT SPEC.	DRAW NO.
SCALE NONE	SIZE A7	R6593304-X0001T-H
SHEET 2 OF 2	REV. A	