

REV.	DESCRIPTION	DATE
A	RELEASE	Apr. 02, 2014

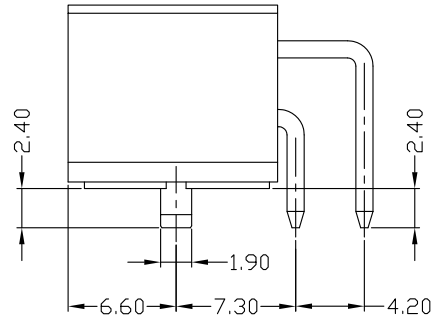
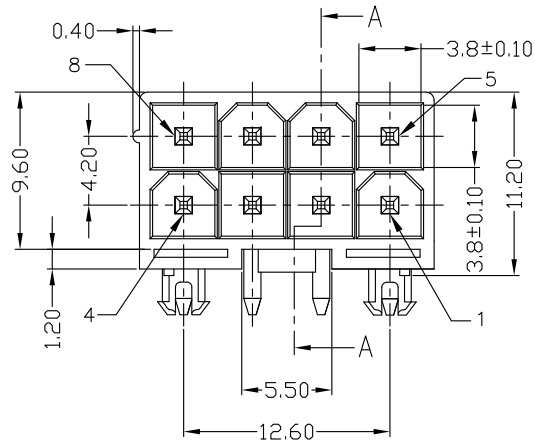

MATERIALS

- HOUSING : L.C.P (UL 94V-0), BLACK.
- TERMINAL : BRASS, S.Q:1.07mm, TIN PLATED OVER NICKEL.

SPECIFICATION

- RATING : 7A MAX PER PIN. AT 12V DC.
- DIELECTRIC WITHSTANDING VOLTAGE : 750V AC R.M.S. FOR ONE MINUTE
- INSULATION RESISTANCE : 1000M OHMS MIN.
- CONTACT RESISTANCE : 30m OHMS MAX.
- OPERATING TEMPERATURE : -55°C TO +105°C.
- RESISTANCE WAVE SOLDERING HEAT 265±5°C FOR 5±0.5 SECONDS.

PART NUMBER INFORMATION:

6652208-T0009T-H

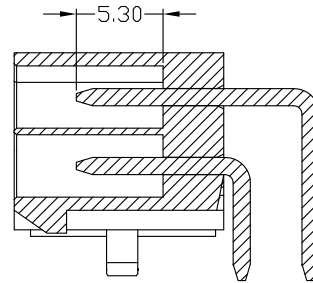
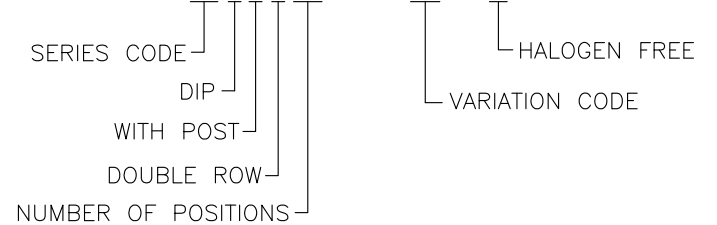

SECTION A-A

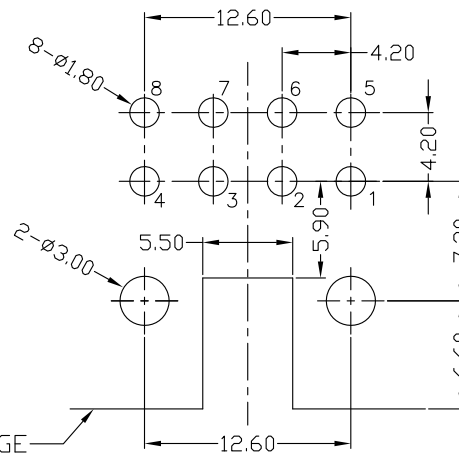
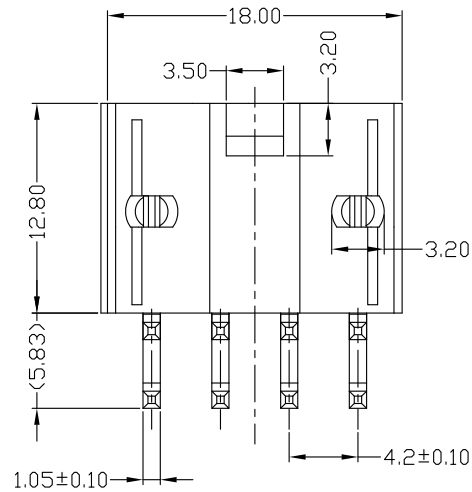

RECOMMEND P.C.B. LAYOUT
TOP VIEW
TOLERANCE ±0.05 mm

TOLERANCE .0=±0.30 .00=±0.20 .000=±XXX ANG=±3°		DRAWER <i>KENNY</i>	 WWW.ASTRON.COM.TW
UNITS : mm		CHECK <i>ERFB</i>	
SCALE NONE		APP'D <i>ALAN</i>	NAME ATX POWER CONNECTOR 2X4 PIN, RIGHT ANGLE, DIP TYPE RECEPTACLE, REVERSE TYPE
SIZE A4		PRODUCT SPEC. ---	DRAW NO. 6652208-T0009T-H
SHEET 1 OF 1		REV. A	08031