

REV.	DESCRIPTION	DATE
E	N13'03010	Mar.04,2013
F	N14'09018	Sep.11.2014
G	N16'01008	Jan.27.2016
H	N17'07004	Aug.07.2017

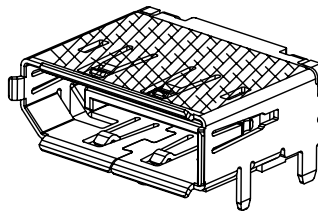
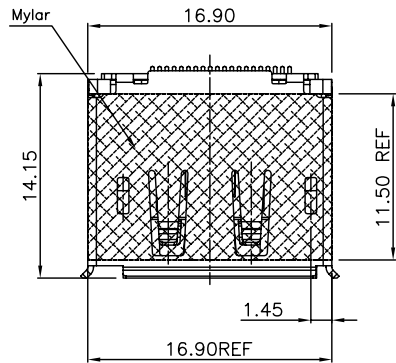

MATERIALS

- HOUSING : THERMOPLASTIC (UL 94V-0) BLACK.
- TERMINAL : BRASS.
PLATING : GOLD PLATED ON CONTACT AREA.
GOLD FLASH PLATED ON SOLDER TAILS.
- SHELL : COPPER ALLOY,
PLATING : NICKEL PLATED OVERALL.
- MYLAR : POLYESTER FILM.

SPECIFICATION

- CURRENT RATING : 0.5A. MAX.
- DIELECTRIC WITHSTANDING VOLTAGE :
500V AC R.M.S. FOR ONE MINUTE.
- INSULATION RESISTANCE : 100MΩ MIN.AT 500V DC.
- CONTACT RESISTANCE : 30mΩ MAX.
- OPERATING TEMPERATURE : -25°C TO +85°C.
- DURABILITY : 10000 CYCLES.
- MATING FORCE : 4.5kgf MAX.
- UNMATING FORCE : 1.0kgf MIN.

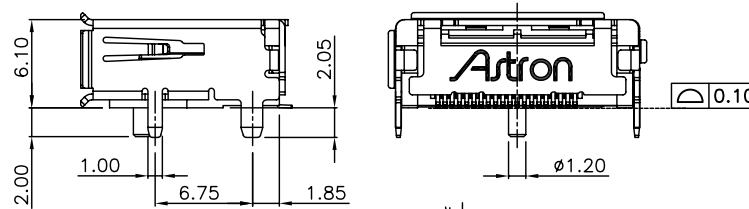
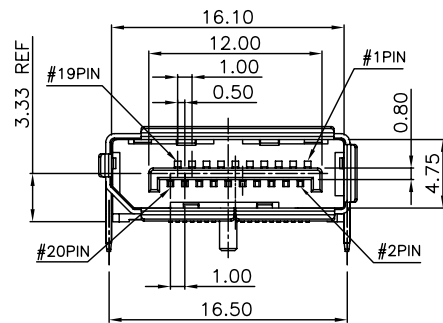

PART NUMBER INFORMATION

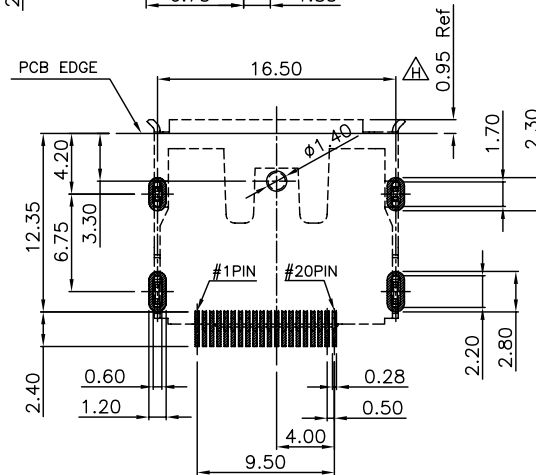
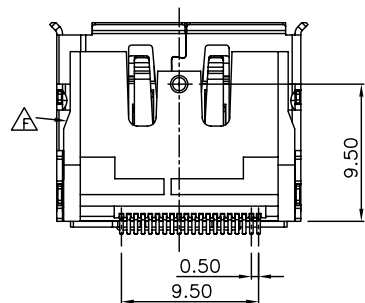
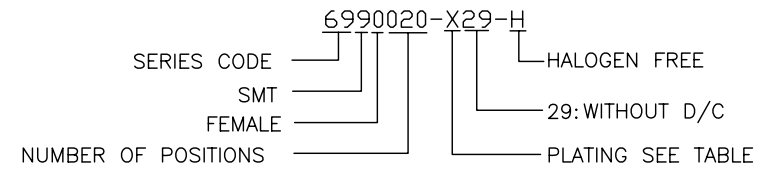

RECOMMEND PCB LAYOUT
TOLERANCE: ±0.05
TOP VIEW

DESCRIPTION OF PLATING ON TERMINALS			
NO.	EXPLAIN	NO.	EXPLAIN
0	GOLD FLASH	3	GOLD 15u''
6	GOLD 30u''		

TOLERANCE .0=±0.25 .00=±0.15 .000=±0.05 ANG.=±3'	DRAWER <i>BHN</i> CHECK <i>Stony</i> APP'D <i>Stony</i>	 ASTRON TECHNOLOGY CORP. NAME DISPLAY PORT R/A SMT TYPE FEMALE-STANDARD WITH MYLAR		
 UNITS : mm	PRODUCT SPEC.			
SCALE NONE	SIZE A6	SHEET 1 OF 2	REV. H	DRAW NO. R6990020-X29-H

REV.	DESCRIPTION	DATE
E	N13'03010	Mar.04,2013
F	N14'09018	Sep.11.2014
G	N16'01008	Jan.27.2016
H	N17'07004	Aug.07.2017

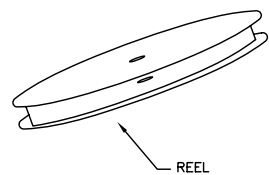
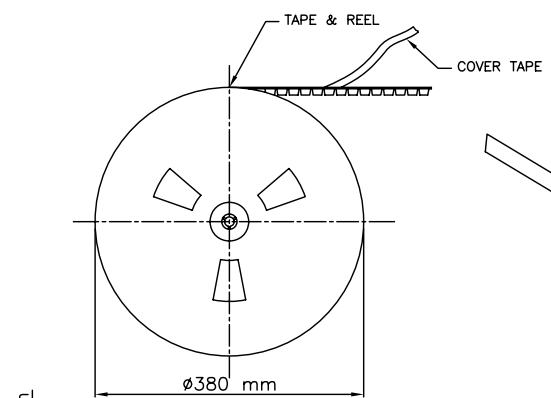
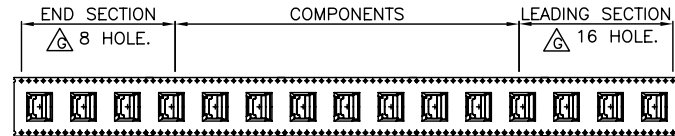

PULL PUT DIRECTION →

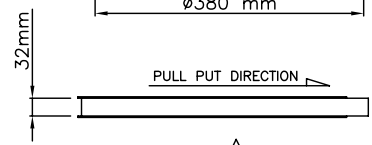

TAPE & PACKAGE :

MATERIAL :

1. CARRIER TAPE : PS
2. COVER TAPE: PE
3. REEL : PS

QUANTITY:

1. 300 PCS/REEL
2. 10 REEL/CARTON: 3000PCS

DIMENSION :

- REEL SIZE :
 DIA=380.0mm, W=32.0mm
 CARTON :
 L=400mm, W=400mm, H=400mm

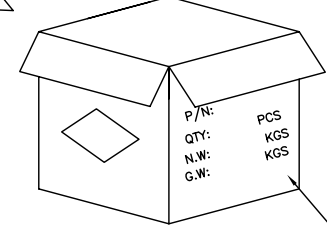
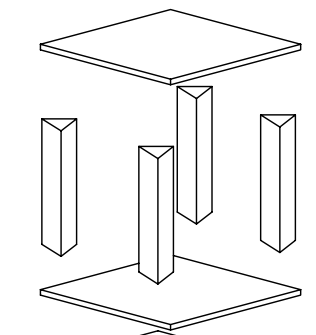
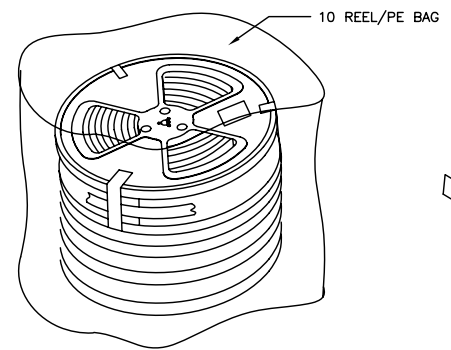
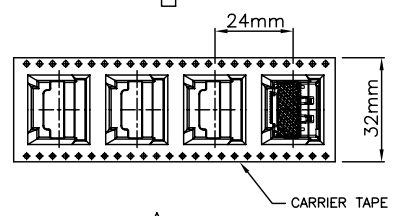

CARTON

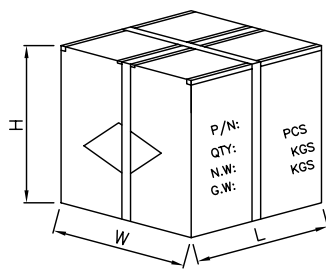

TOLERANCE .0=±0.25 .00=±0.15 .000=±0.05 ANG.=±3°		DRAWER <i>BH&N</i> CHECK <i>Stony</i> APP'D <i>Stony</i>		 ASTRON TECHNOLOGY CORP. NAME DISPLAY PORT R/A SMT TYPE FEMALE-STANDARD WITH MYLAR	
UNITS : mm		PRODUCT SPEC. —			
SCALE NONE	SIZE A6	SHEET 2 OF 2	REV. H	DRAW NO. R6990020-X29-H	