

| REV. | DESCRIPTION | DATE        |
|------|-------------|-------------|
| A    | N17'07008   | Jul.13,2017 |
|      |             |             |

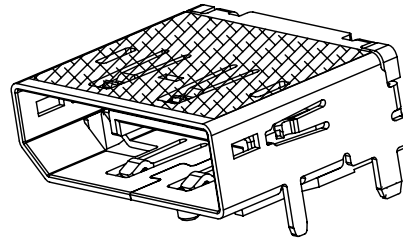
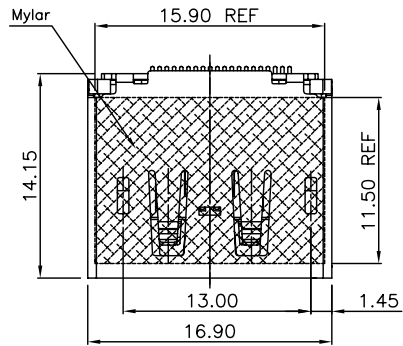

### MATERIALS

- HOUSING : THERMOPLASTIC (UL 94V-0) BLACK.
- TERMINAL : BRASS.  
PLATING : GOLD PLATED ON CONTACT AREA.  
GOLD FLASH PLATED ON SOLDER TAILS.
- SHELL : COPPER ALLOY,  
PLATING : NICKEL PLATED OVERALL.
- MYLAR : POLYESTER FILM.

### SPECIFICATION

- CURRENT RATING : 0.5A. MAX.
- DIELECTRIC WITHSTANDING VOLTAGE :  
500V AC R.M.S. FOR ONE MINUTE.
- INSULATION RESISTANCE : 100MΩ MIN.AT 500V DC.
- CONTACT RESISTANCE : 30mΩ MAX.
- OPERATING TEMPERATURE : -25°C TO +85°C.
- DURABILITY : 10000 CYCLES.
- MATING FORCE : 4.5kgf MAX.
- UNMATING FORCE : 1.0kgf MIN.

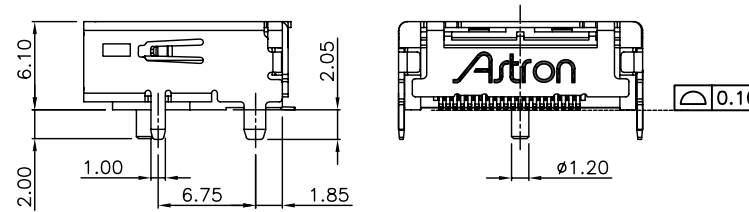
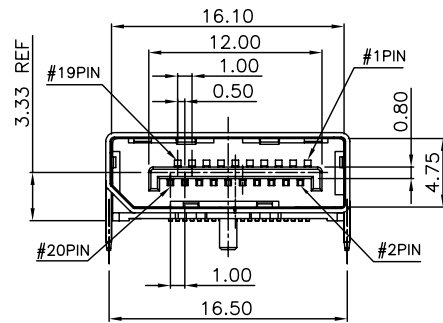

### PART NUMBER INFORMATION

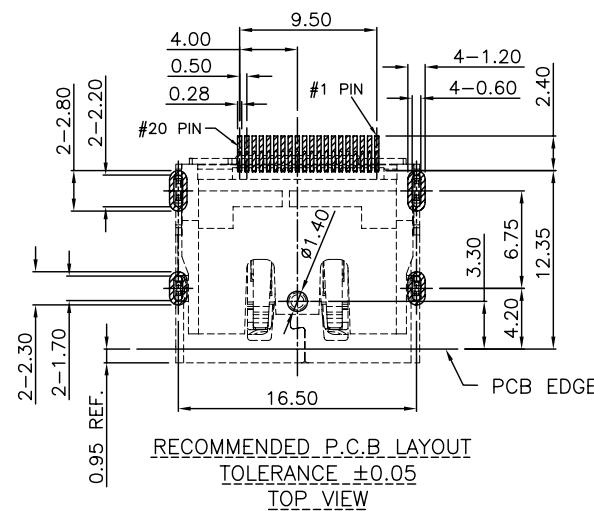
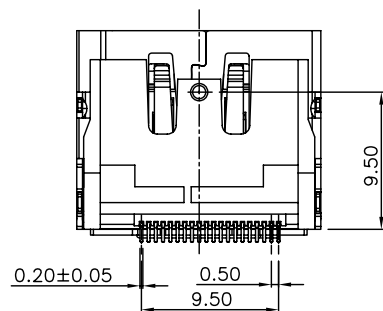
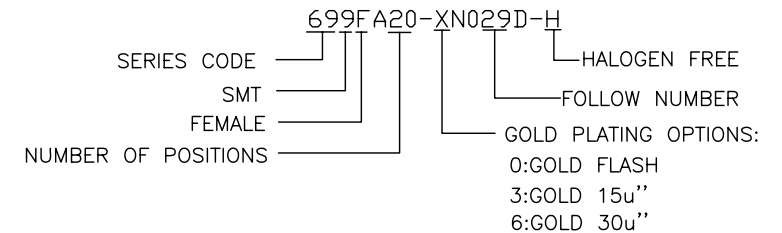

|  |            |                   |           |  |
|--|------------|-------------------|-----------|--|
| TOLERANCE<br>.0=±0.25<br>.00=±0.15<br>.000=±0.05<br>ANG.=±3° |            | DRAWER<br>CHECK   |           | <b>Astron</b><br>ASTRON TECHNOLOGY CORP. |
| APP'D  |            | NAME              |           |  |
| PRODUCT SPEC.  |            | DRAW NO.          |           | DISPLAY PORT R/A SMT TYPE.<br>FEMALE     |
| UNITS : mm   |            | R699FA20-XN029D-H |           |  |
| SCALE<br>NONE  | SIZE<br>A6 | SHEET<br>1 OF 1   | REV.<br>A |  |