

REV.	DESCRIPTION	DATE
1	PROPOSAL	Mar. 20, 2019

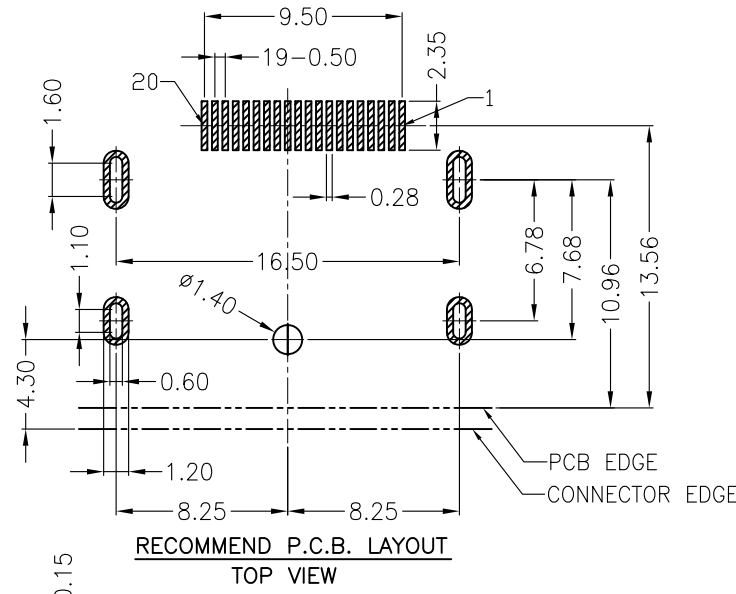
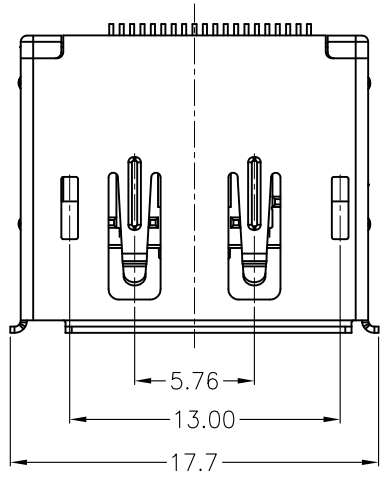

MATERIALS:

1. HOUSING : LCP (UL 94V-0), BLACK.
2. TERMINAL : BRASS, AU PLATED ON CONTACT AREA, TIN 100u" PLATED ON SOLDER TAIL, UNDER NICKEL 50u" PLATED OVER ALL.
3. SHELL : STAINLESS STEEL, NICKEL 50u" PLATING.

SPECIFICATION

1. RATING VOLTAGE : 40V AC
2. CURRENT RATING : 0.5A MIN.
3. DIELECTRIC WITHSTANDING VOLTAGE : 500V AC R.M.S. FOR ONE MINUTE.
4. INSULATION RESISTANCE : 100M OHMS MIN. AT 500V DC.
5. CONTACT RESISTANCE : 30m OHMS MAX.
6. OPERATING TEMPERATURE : -40°C TO +85°C.
7. INSERTION FORCE : 4.5kgf MAX.
8. EXTRACTION FORCE : 1.0kgf ~ 4.0kgf
9. DURABILITY : 10,000 CYCLES.
10. RESISTANCE WAVE SOLDERING HEAT : 265±5 °C FOR 5 SECONDS.

PART NUMBER INFORMATION:

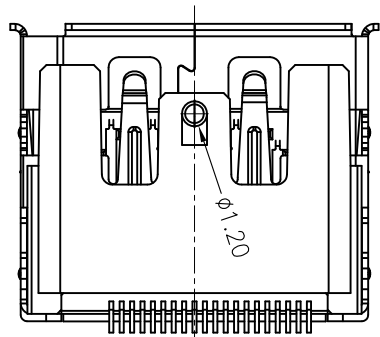
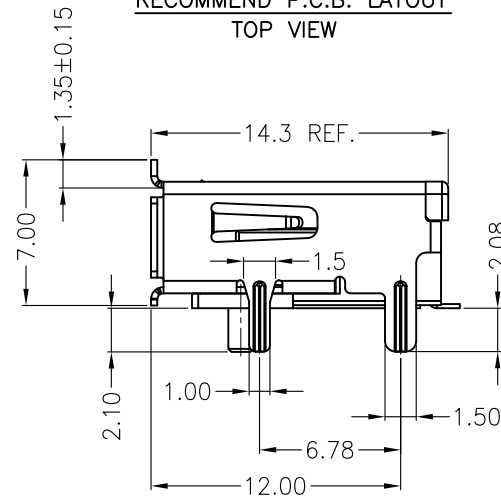
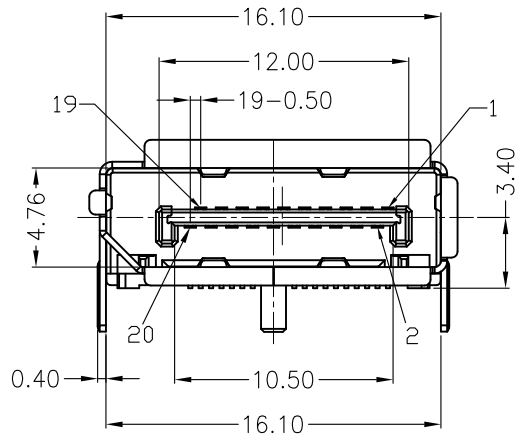
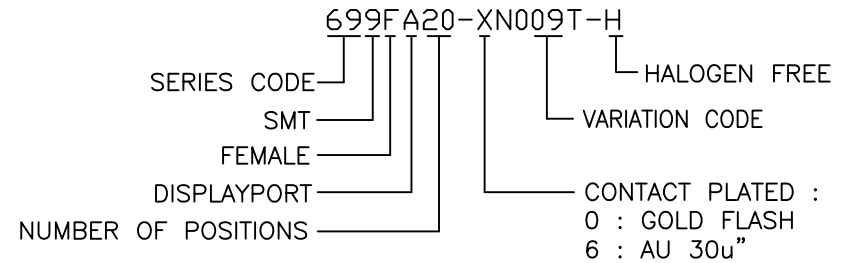

TOLERANCE .0=±0.30 .00=±0.25 .000=± ANG.=±3'	DRAWER <i>BINDY</i>	 ASTRON TECHNOLOGY CORP. NAME DISPLAYPORT SMT TYPE FEMALE DRAW NO. 699FA20-XN009T-H
	CHECK <i>JOE</i>	
 UNITS : mm SCALE NONE SIZE A4	APP'D <i>ALAN</i>	DRAW NO. 699FA20-XN009T-H
	PRODUCT SPEC. ---	12008 910031
SHEET 1 OF 2	REV. 2	

REV.	DESCRIPTION	DATE
1	PROPOSAL	Mar. 20, 2019

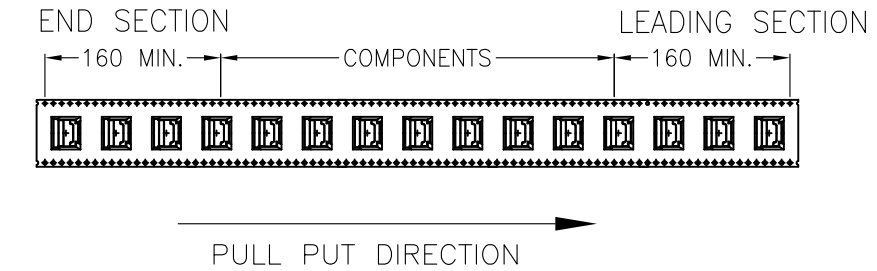
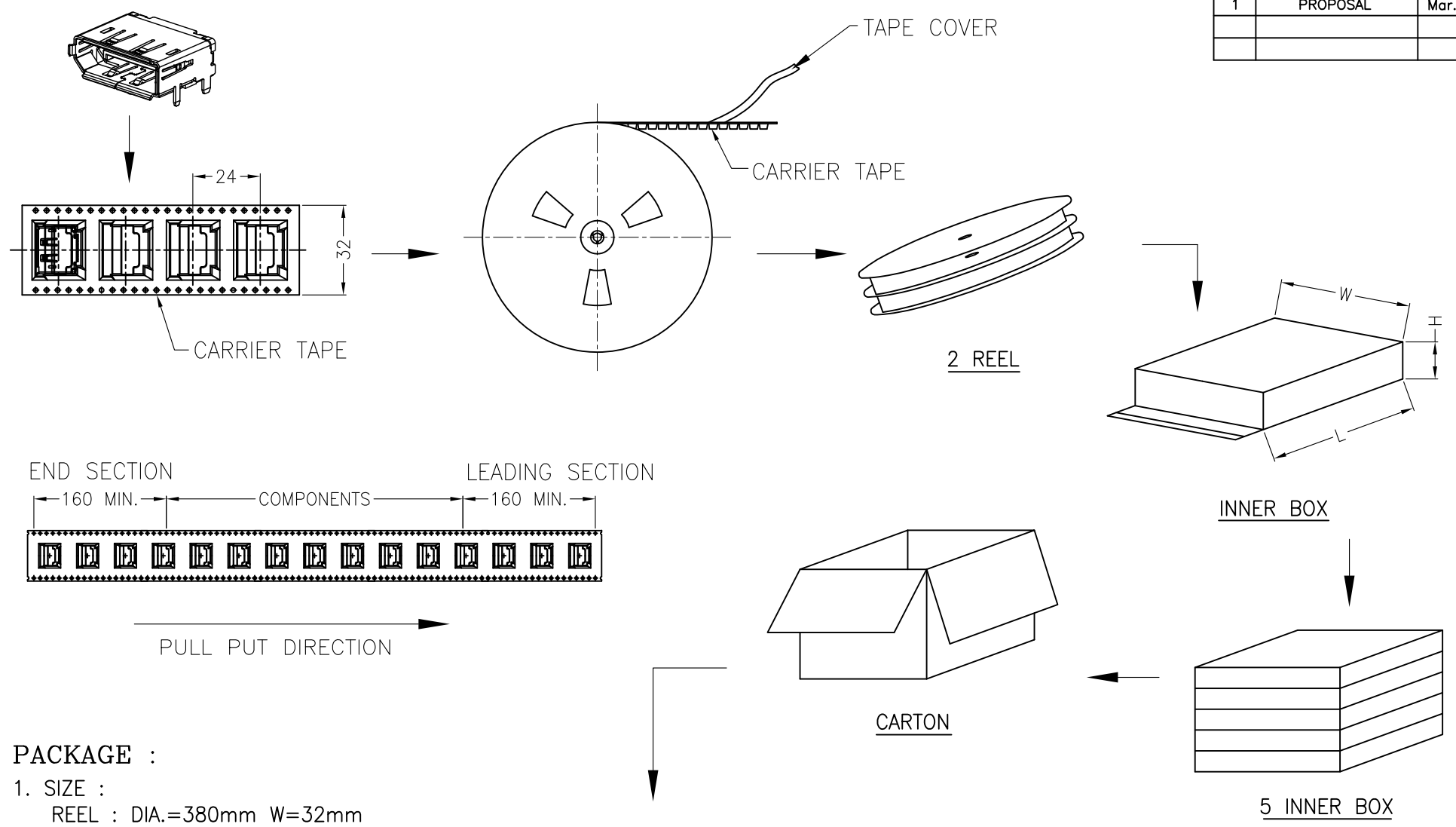

PACKAGE :

1. SIZE :
 REEL : DIA.=380mm W=32mm
 INNER BOX : 387x387x85mm (LxWxH)
 CORTON : 420x400x460mm (LxWxH)
2. QUANTITY :
 300 PCS/REEL
 2 REEL/INNER BOX= 600PCS
 5 INNER BOX/CARTON= 3000PCS

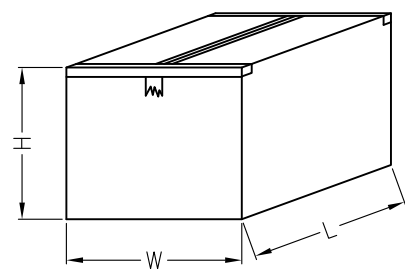

TOLERANCE .0=±XXX .00=±XXX .000=± ANG.=±3'		DRAWER <i>BINDY</i>		Astron ASTRON TECHNOLOGY CORP.
UNITS : mm		CHECK <i>JOE</i>		
SCALE NONE		APP'D <i>ALAN</i>		NAME DISPLAYPORT SMT TYPE FEMALE
SIZE A4		PRODUCT SPEC. ---		DRAW NO. 699FA20-XN009T-H
SHEET 2 OF 2		REV. 2		12008 910031