

REV.	DESCRIPTION	DATE
J	N15'09010	Sep.30.2015
K	N16'01008	Jan.27.2016
L	N16'04009	Apr.11.2016
M	N16'04018	Apr.25.2016

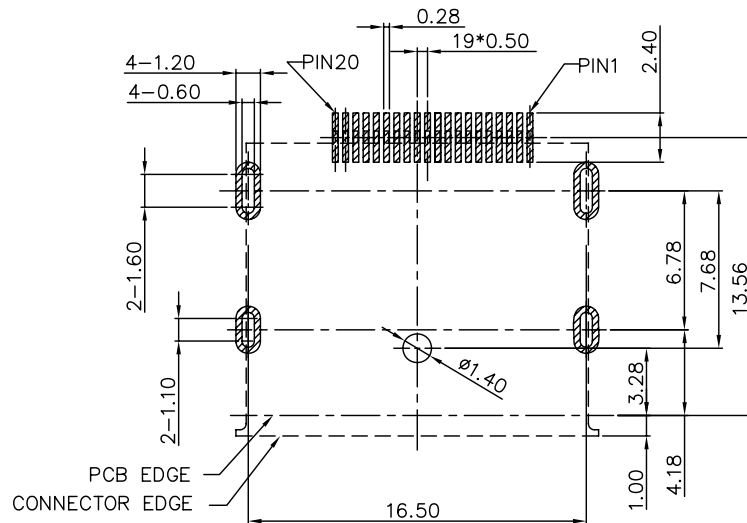
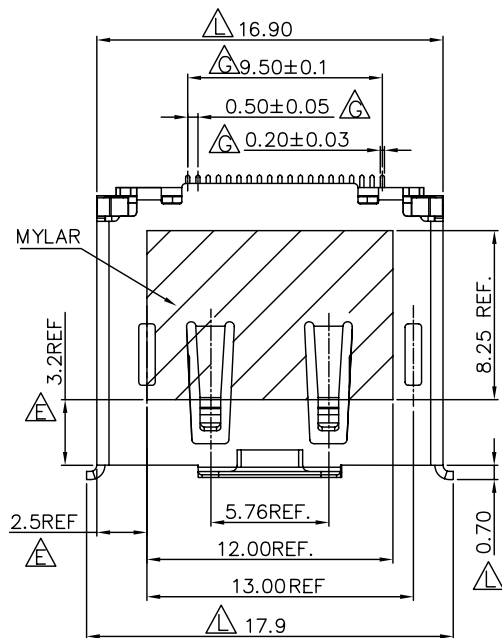

RECOMMEND PCB LAYOUT
TOLERANCE: ±0.05
TOP VIEW

MATERIALS:

- HOUSING: THERMOPLASTIC (UL94V-0),BLACK
- TERMINAL: COPPER ALLOY
PLATING : GOLD PLATED .
- SHELL: COPPER ALLOY , T=0.40mm
PLATING : NICKEL PLATED OVERALL.

SPECIFICATION

- CURRENT RATING : 0.5 A MAX.
- DIELECTRIC WITHSTANDING VOLTAGE :
500V AC R.M.S. FOR ONE MINUTE.
- CONTACT RESISTANCE : 30mΩ MAX.
- INSULATION RESISTANCE :
100MΩ MIN. AT 500V DC.
- OPERATING TEMPERATURE : -20°C TO +85°C.

PART NUMBER INFORMATION:

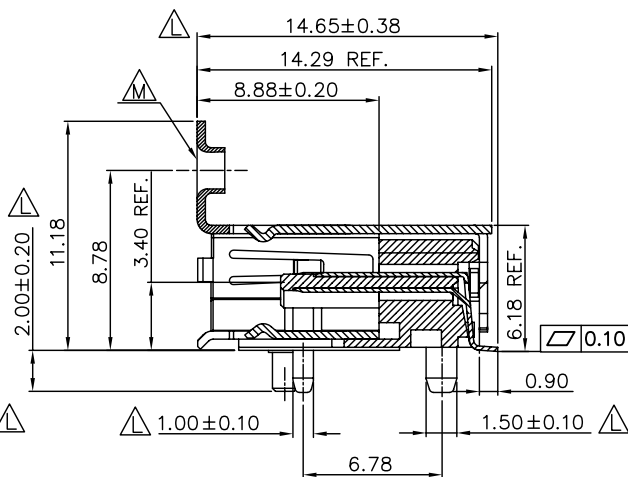
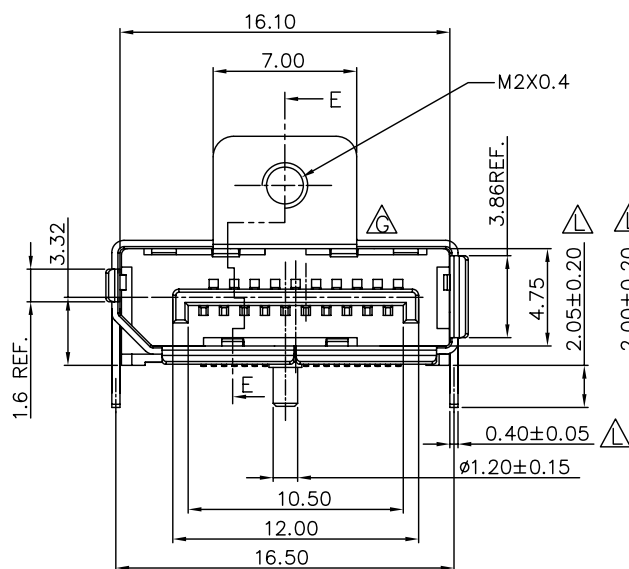
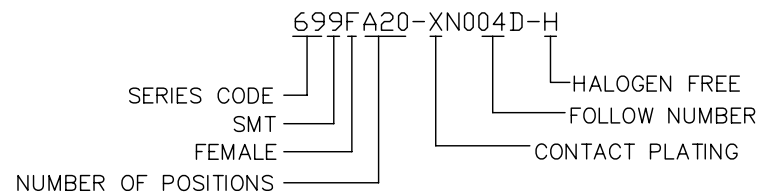

SECTION E-E

DESCRIPTION OF PLATING ON TERMINALS			
NO.	EXPLAIN	NO.	
0	GOLD FLASH	3	GOLD 15u"
6	GOLD 30u"		

TOLERANCE .0=±0.38 .00=±0.25 .000=±0.05 ANG.=±3°	DRAWER <i>Duan</i>	 ASTRON TECHNOLOGY CORP.
	CHECK <i>Shony</i>	
 UNITS : mm	APP'D <i>Shony</i>	DRAW NO. R699FA20-XN004D-H
	PRODUCT SPEC. _____	SCALE NONE SIZE A7 SHEET 1 OF 2 REV. M

REV.	DESCRIPTION	DATE
J	N15'09010	Sep.30.2015
K	N16'01008	Jan.27.2016
L	N16'04009	Apr.11.2016
M	N16'04018	Apr.25.2016

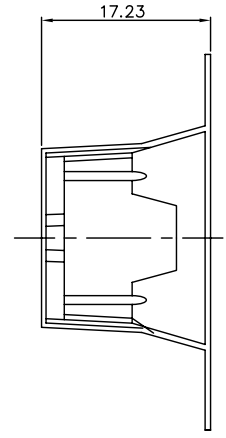
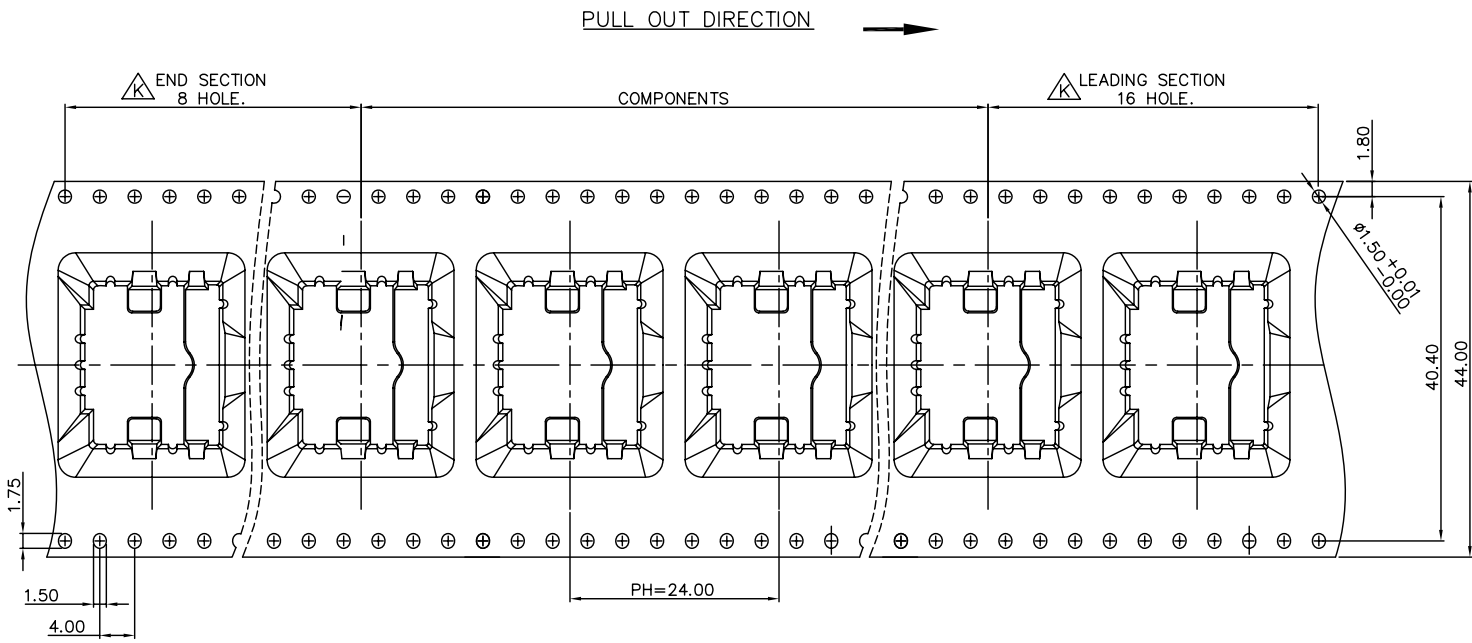

TAPE & REEL PACKAGE :

MATERIALS

1. CARRIER TAPE: POLYSTYREN (PS)
2. COVER TAPE: POLYSTYREN (PS)
3. REEL: POLYSTYREN (PS)

QUANTITY

- △ 1. 250PCS PER REEL
- △ 2. 5 REEL PER CARTON(1250PCS PER CARTON)
- △ (CARTON :L=400mm, W=400mm, H=270mm)

PULL OUT DIRECTION

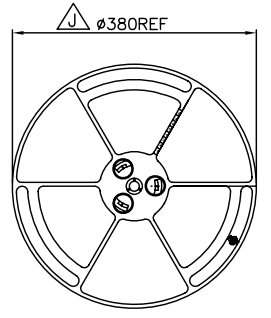

REEL FOR CARRIER TAPE

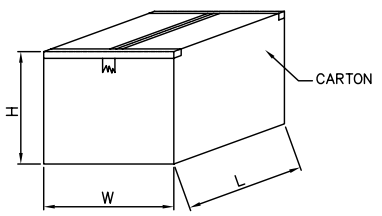
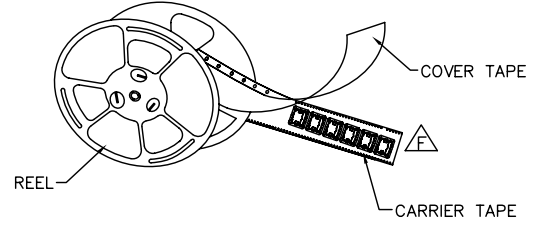
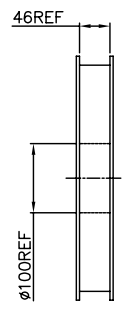

TOLERANCE .0=±0.38 .00=±0.25 .000=±0.05 ANG.=±3°	DRAWER <i>Duan</i>	 ASTRON TECHNOLOGY CORP.
	CHECK <i>Shony</i>	
 UNITS : mm	APP'D <i>Shony</i>	DRAW NO. R699FA20-XN004D-H
	SCALE NONE	SIZE A7
	REV. M	