

REV.	DESCRIPTION	DATE
C	MODIFY DIM	May.08, 2019
D	MODIFY DIM	May.28, 2019
E	N19'12002	Dec.10, 2019
F	ADD P/N	Jun.01, 2020

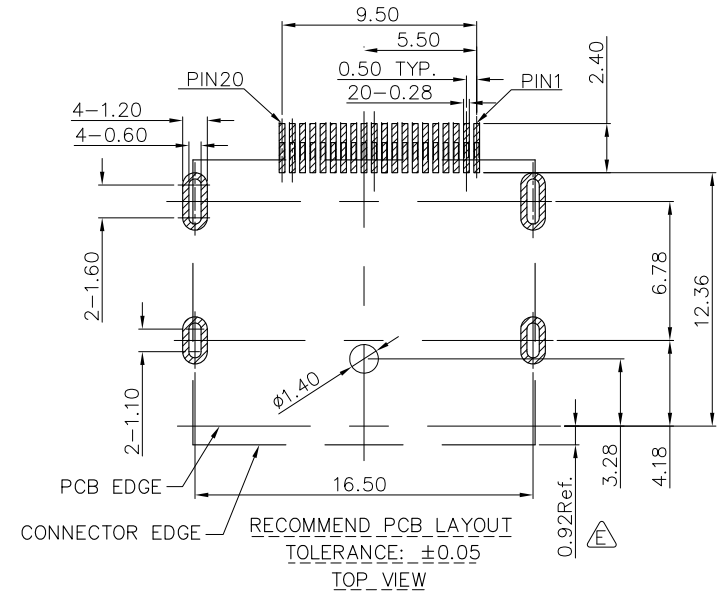
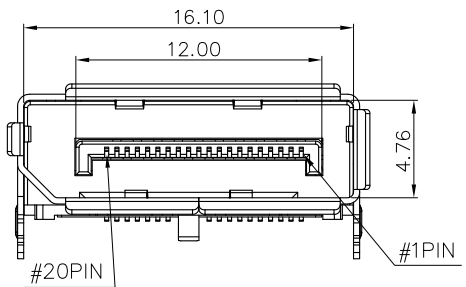
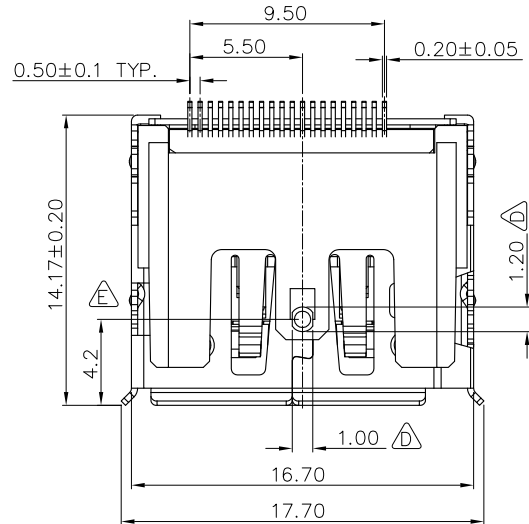
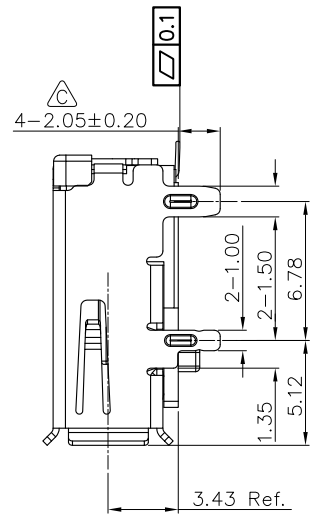
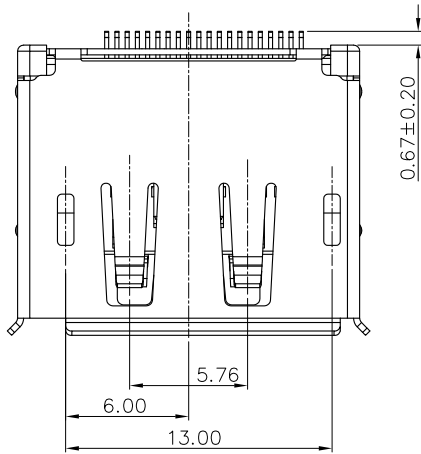
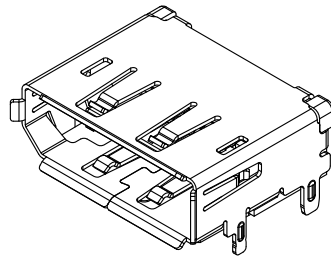
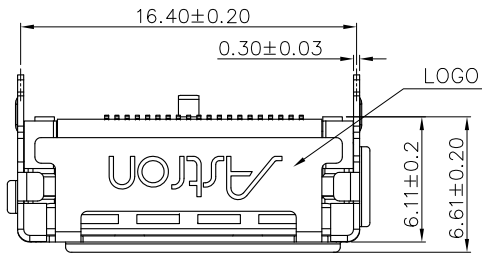

**MATERIALS**

- HOUSING: LCP (UL94V-0), BLACK.
- TERMINAL: COPPER ALLOY, GOLD PLATED ON CONTACT AREA, TIN PLATED 80u" ON SOLDER TAILS. NICKEL PLATED 50u" OVERALL.
- SHELL: STAINLESS STEEL, NICKEL PLATED 40u" OVERALL.

**SPECIFICATION**

- CURRENT RATING: 0.5A. MAX.
- DIELECTRIC WITHSTANDING VOLTAGE: 500V AC R.M.S. FOR ONE MINUTE.
- INSULATION RESISTANCE: 100MΩ MIN. AT 500V DC.
- CONTACT RESISTANCE: 30mΩ MAX.
- OPERATING TEMPERATURE: -25°C TO +85°C.
- DURABILITY: 10000 CYCLES.
- MATING FORCE: 4.5kgf MAX.
- UNMATING FORCE: 1.0kgf MIN.

**PART NUMBER INFORMATION:**

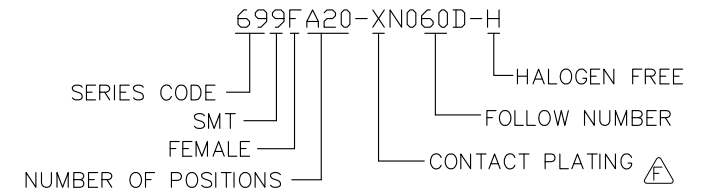

**DESCRIPTION OF PLATING ON TERMINALS**

NO.	EXPLAIN	NO.	
0	GOLD FLASH	1	GOLD 1~3u"
3	GOLD 15u"	6	GOLD 30u"

<b>TOLERANCE</b> .0=±0.25 .00=±0.15 .000=±0.05 ANG.=±3°	DRAWER <i>Chen</i>	 ASTRON TECHNOLOGY CORP.
	CHECK <i>Flory</i>	
 PRODUCT SPEC.	APP'D <i>Flory</i>	DRAW NO. R699FA20-XN060D-H
UNITS : mm	SCALE NONE SIZE A4	SHEET 1 OF 2 REV. F

REV.	DESCRIPTION	DATE
C	MODIFY DIM	May.08, 2019
D	MODIFY DIM	May.28, 2019
E	N19'12002	Dec.10, 2019
F	ADD P/N	Jun.01, 2020

B

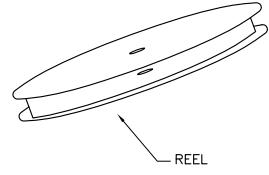
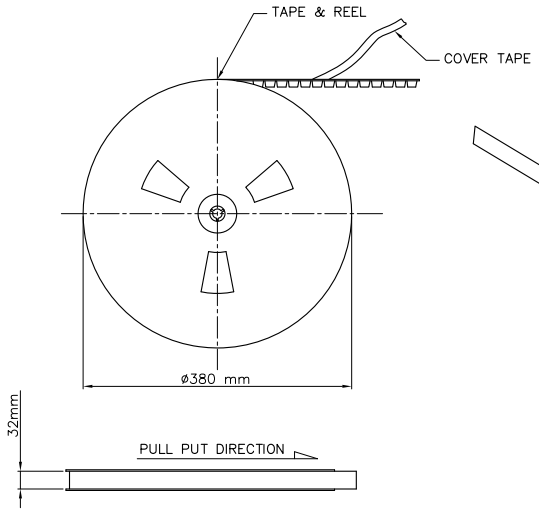
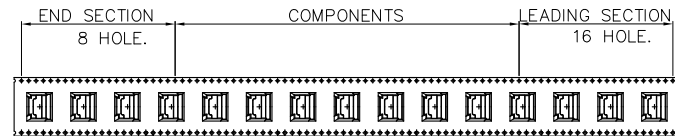

PULL PUT DIRECTION

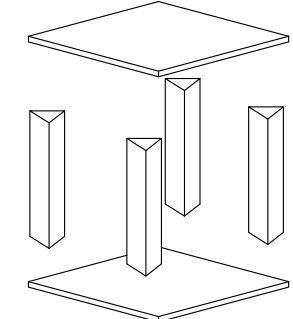
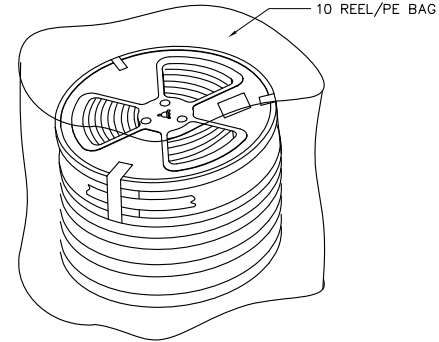
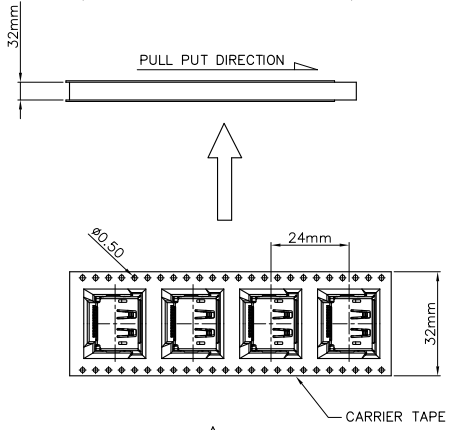

**TAPE & PACKAGE :**

**MATERIAL :**

1. CARRIER TAPE : PS
2. COVER TAPE: PE
3. REEL : PS

**QUANTITY:**

1. 350 PCS/REEL
2. 10 REEL/CARTON: 3500PCS

**DIMENSION :**

- REEL SIZE :  
DIA=380.0mm, W=32.0mm
- CARTON :  
L=400mm, W=400mm, H=400mm

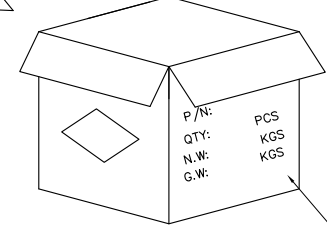

CARTON

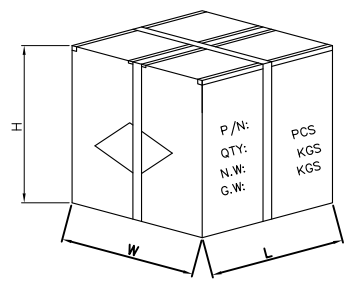
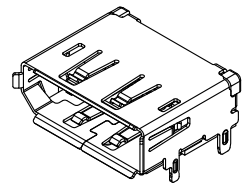

<p><b>TOLERANCE</b></p> <p>.0=±0.25 .00=±0.15 .000=±0.05 ANG.=±3'</p>	<p><b>DRAWER</b></p> <p>Shen</p>		<p><b>Astron</b></p> <p>ASTRON TECHNOLOGY CORP.</p>
	<p><b>CHECK</b></p> <p>Stony</p>		
<p><b>UNITS : mm</b></p>	<p><b>APP'D</b></p> <p>Stony</p>		<p><b>NAME</b></p> <p>DISPLAY PORT R/A SMT TYPE. FEMALE, WITH LOGO</p>
	<p><b>PRODUCT SPEC.</b></p> <p>—</p>		<p><b>DRAW NO.</b></p> <p>R699FA20-XN060D-H</p>
<p><b>SCALE</b></p> <p>NONE</p>	<p><b>SIZE</b></p> <p>A4</p>	<p><b>SHEET</b></p> <p>2 OF 2</p>	<p><b>REV.</b></p> <p>F</p>