

REV.	DESCRIPTION	DATE
A	N16'05013	May.20, 2016
B	N20'08009	Aug.31, 2020
C	MODIFY DRAWING	Jul.09, 2021

MATERIALS

- HOUSING & COVER : L.C.P, (UL 94V-0), BLACK.
- TERMINAL : BRASS,
GOLD FLASH PLATED ON CONTACT AREA,
TIN PLATED ON SOLDER TAILS,
UNDER NICKEL PLATED.
- SHELL : BRASS, NICKEL PLATED OVERALL.

SPECIFICATION

- CURRENT RATING : 0.5A MIN.
- DIELECTRIC WITHSTANDING VOLTAGE :
500V AC R.M.S. FOR ONE MINUTE.
- CONTACT RESISTANCE : 30mΩ MAX.
- INSULATION RESISTANCE : 100MΩ MIN. AT 500V DC.
- OPERATING TEMPERATURE : -25°C TO +85°C.
- DURABILITY : 10000 CYCLES.
- MATING FORCE : 4.5Kgf MAX.
- UNMATING FORCE : 1.0Kgf~4.0Kgf.

PART NUMBER INFORMATION :

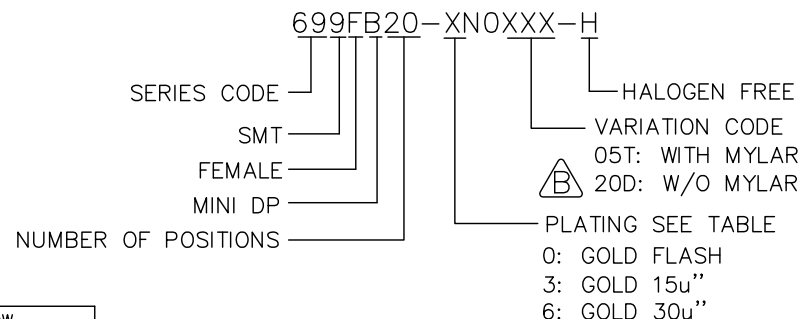

PIN ASSIGNMENT

TOP ROW			BOTTOM ROW		
PIN	SIGNAL	NAME	PIN	SIGNAL	NAME
1	GND	GND	2	Out	Hot Plug Detect
3	In	ML_Lane3 (n)	4	CONFIG	CONFIG1
5	In	ML_Lane3 (p)	6	CONFIG	CONFIG2
7	GND	GND	8	GND	GND
9	In	ML_Lane2 (n)	10	In	ML_Lane0 (n)
11	In	ML_Lane2 (p)	12	In	ML_Lane0 (p)
13	GND	GND	14	GND	GND
15	In	ML_Lane1 (n)	16	I/O	AUX_CH (p)
17	In	ML_Lane1 (p)	18	I/O	AUX_CH (n)
19	GND	GND	20	PWR Out	DP_PWR

TOLERANCE
.0=±0.25
.00=±0.15
.000=±0.05
ANG.=±3°

UNITS : mm

SCALE NONE SIZE A4

DRAWER Chen

CHECK Stony

APP'D Stony

PRODUCT SPEC.

SHEET 1 OF 2

REV. C

Astron
WWW.ASTRON.COM.TW

NAME
MINI DP 20PIN SMT FEMALE
W/O SPRING

DRAW NO.
699FB20-XN005T(20D)-H

T0123

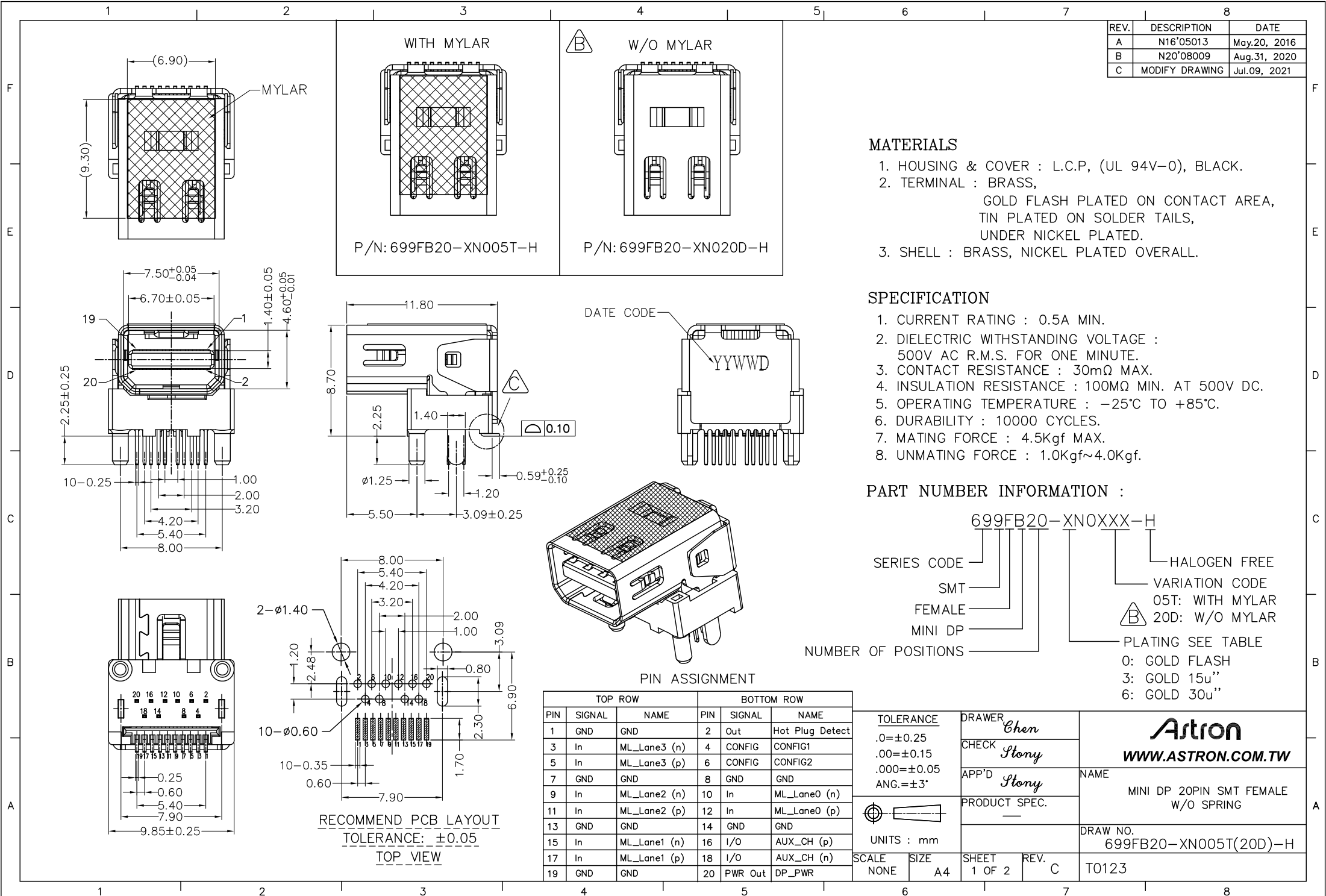

WITH MYLAR

P/N: 699FB20-XN005T-H

B

W/O MYLAR

P/N: 699FB20-XN020D-H

DATE CODE

YYWW

C

0.10

RECOMMEND PCB LAYOUT
TOLERANCE: ±0.05
TOP VIEW

REV.	DESCRIPTION	DATE
A	N16'05013	May.20, 2016
B	N20'08009	Aug.31, 2020
C	MODIFY DRAWING	Jul.09, 2021

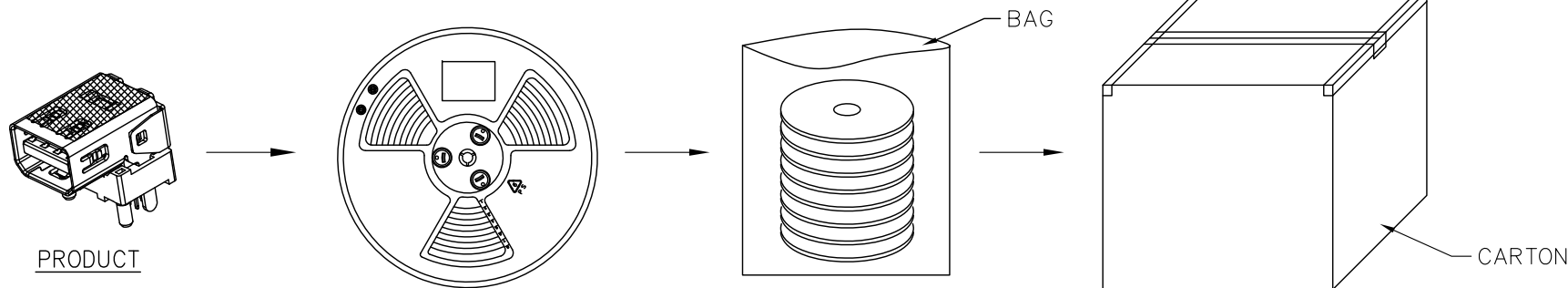
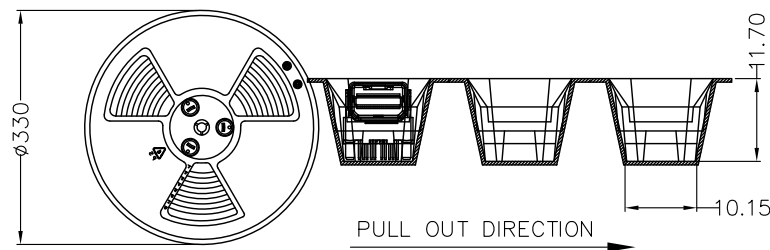
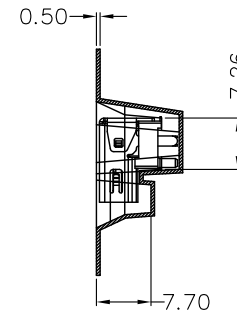
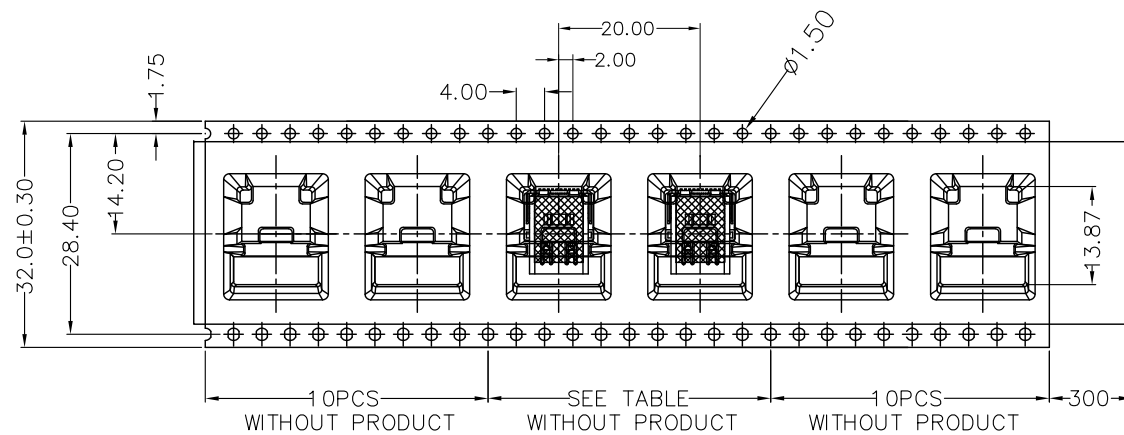

PACKAGE :

1. SIZE :

REEL : DIA.=330mm
 CORTON : 350x350x325mm (LxWxH)

2. QUANTITY :

250 PCS/REEL
 8 REEL/CARTON = 2000PCS

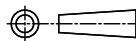
TOLERANCE .0= ± 0.25 .00= ± 0.15 .000= ± 0.05 ANG.= $\pm 3^\circ$	DRAWER <i>Chen</i>	Astron WWW.ASTRON.COM.TW
	CHECK <i>Hony</i>	
 UNITS : mm	APP'D <i>Hony</i>	DRAW NO. 699FB20-XN005T(20D)-H
	PRODUCT SPEC. ---	DRAW NO. T0123
SCALE NONE	SIZE A4	SHEET 2 OF 2
	REV. C	