

| REV. | DESCRIPTION | DATE |
|------|-------------|---------------|
| A | RELEASE | Oct. 31, 2019 |
| B | MODIFY | Nov. 11, 2019 |
| C | MODIFY | Dec. 05, 2019 |

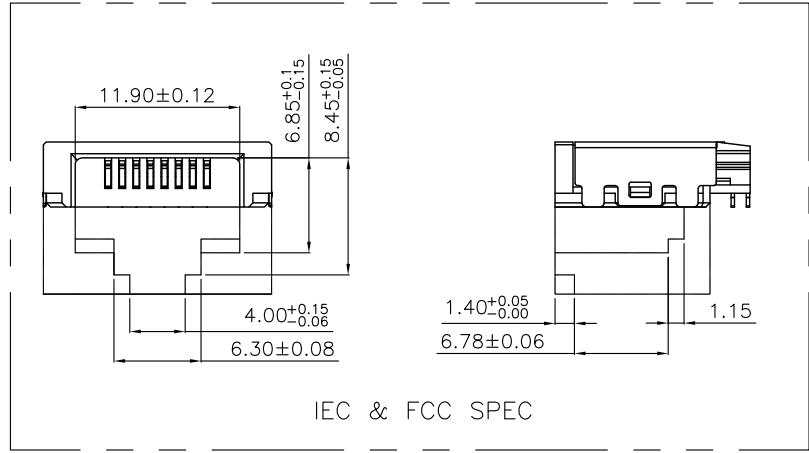
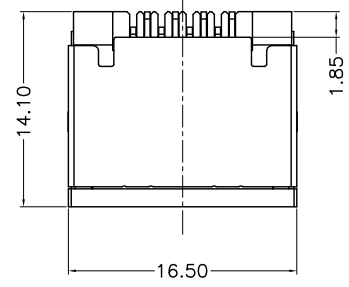

MATERIALS

1. HOUSING : NYLON PA9T (UL 94V-0), BLACK.
2. TERMINSL : COPPER ALLOY t=0.25mm, GOLD FLASH ON CONTACT AREA, TIN ON SOLDER TAIL, NICKEL UNDERPLATING.
3. SHELL : STAINLESS STEEL t=0.20mm, NICKEL PLATING OVER ALL.

SPECIFICATION

1. VOLTAGE RATING : 150V
2. CURRENT RATING : 1.5A
3. INSULATION RESISTANCE : 100M OHMS MIN.
4. CONTACT RESISTANCE : 50m OHMS MAX (INITIAL); 100m OHMS MAX (AFTER TEST).
5. DIELECTRIC WITHSTANDING VOLTAGE : 500V DC.
6. OPERATION TEMPERATURE : -20°C~+85°C.
7. DURABILITY : 5000 CYCLES.
8. MATINGFORCE : 2.25KG MAX WITH LATCH DEPERESSED.

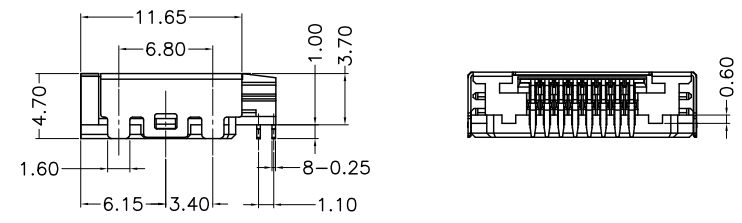
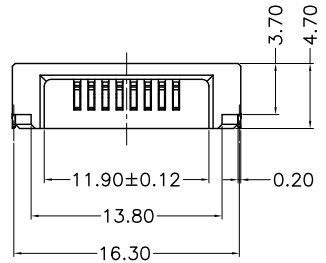

PART NUMBER INFORMATION :

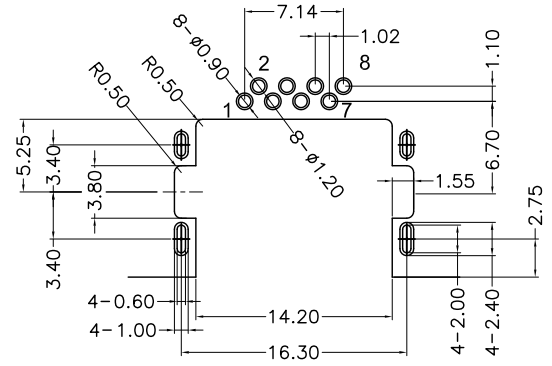
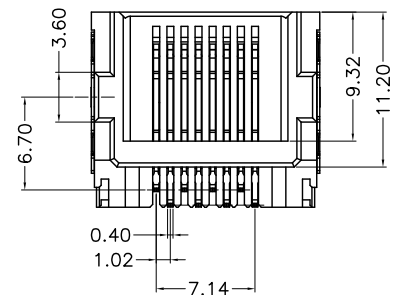
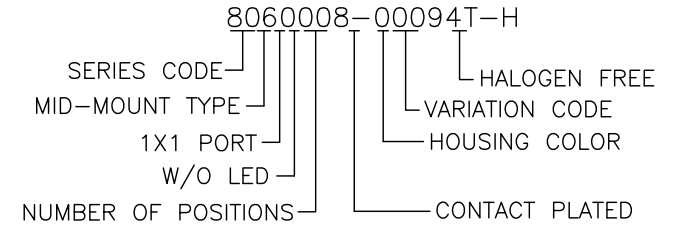

RECOMMENDED PCB LAYOUT
TOLERANCE ±0.05mm (TOP VIEW)

| | | |
|--------------|---------------|-------------------------|
| TOLERANCE | DRAWER | Astron |
| 0. = ±0.50 | <i>LLJ</i> | |
| .0 = ±0.40 | CHECK | ASTRON TECHNOLOGY CORP. |
| .00 = ±0.25 | <i>ERJC</i> | NAME |
| .000 = ±0.15 | APP'D | RJ45 CONNECTOR |
| ANG. = ±3° | <i>ALAN</i> | MID-MOUNT TYPE W/O LED |
| | PRODUCT SPEC. | DRAW NO. |
| UNITS : mm | | 8060008-00094T-H |
| SCALE NONE | SIZE A4 | SHEET 1 OF 2 |
| | | REV. C |
| | | 08031 |

| REV. | DESCRIPTION | DATE |
|------|-------------|---------------|
| A | RELEASE | Oct. 31, 2019 |
| B | MODIFY | Nov. 11, 2019 |
| C | MODIFY | Dec. 05, 2019 |

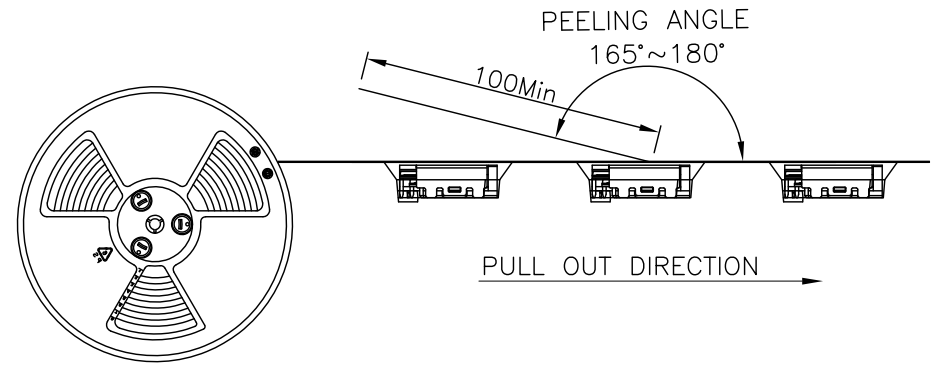
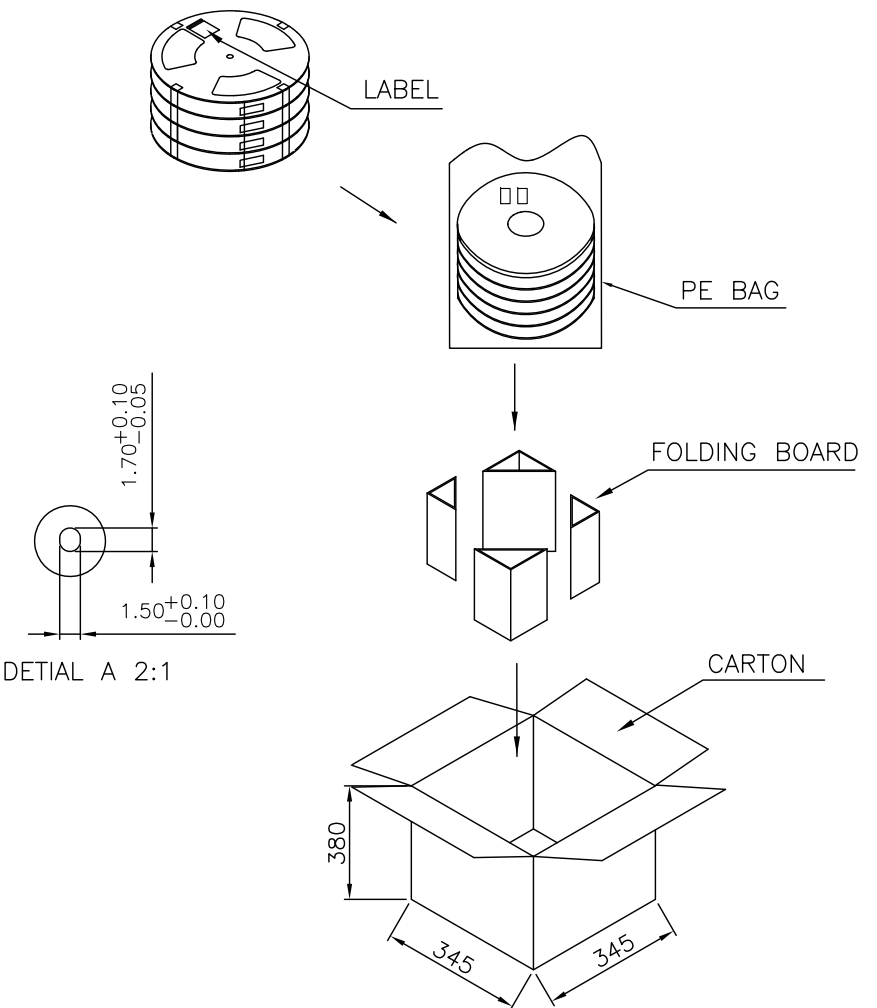
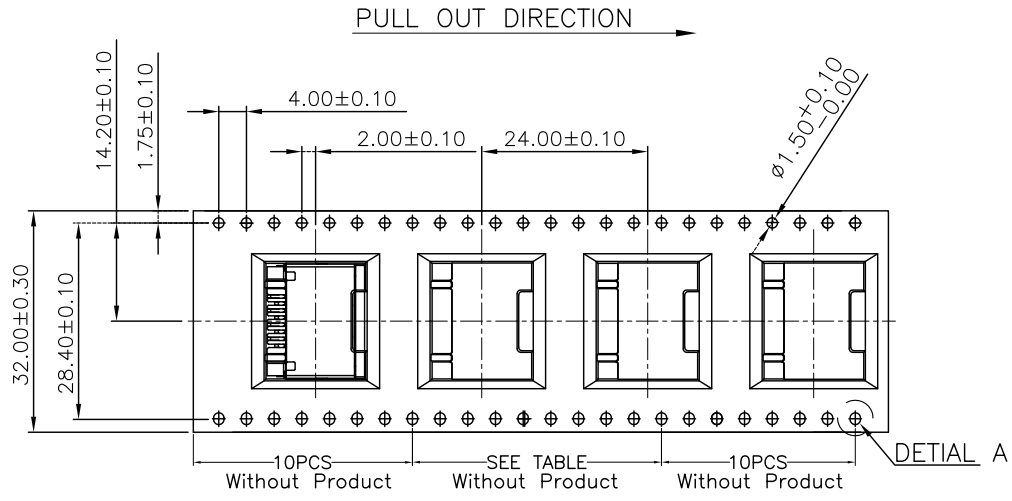

PACKAGE $\triangle C$

1. SIZE :
 REEL : DIA.=330mm
 CORTON : 345x345x380mm (LxWxH)
2. QUANTITY :
 500 PCS/REEL
 10 REEL/CARTON = 5,000 PCS

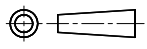
| | | | |
|---|-------------------|-----------------------------|--|
| TOLERANCE 0. =±0.50 .0 =±0.40 .00 =±0.25 .000 =±0.15 ANG. =±3° | | DRAWER <i>LJI</i> | Astron ASTRON TECHNOLOGY CORP. |
|  | | CHECK <i>ERIC</i> | |
| UNITS : mm | | APP'D <i>ALAN</i> | DRAW NO. 8060008-00094T-H |
| SCALE NONE | SIZE A4 | SHEET 2 OF 2 | REV. C |
| | | | 08031 |