

REV.	DESCRIPTION	DATE
A	RELEASE	Oct. 4, 2000
B	DRAW MODIFY	Oct. 20, 2003
C	RoHS MODIFY	Sep. 06, 2005
D	DRAW MODIFY	Apr. 03, 2007

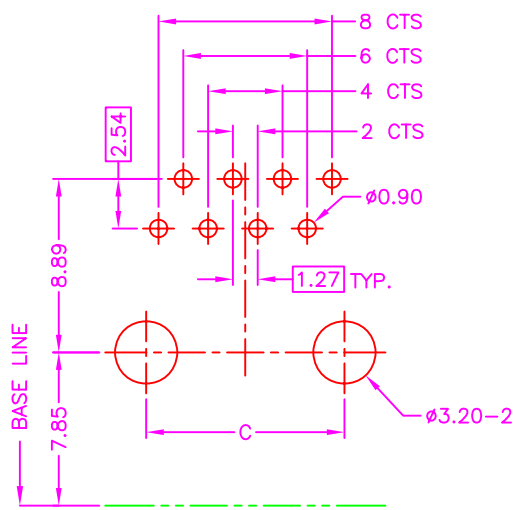
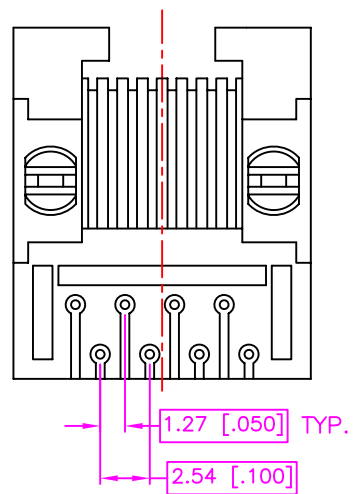
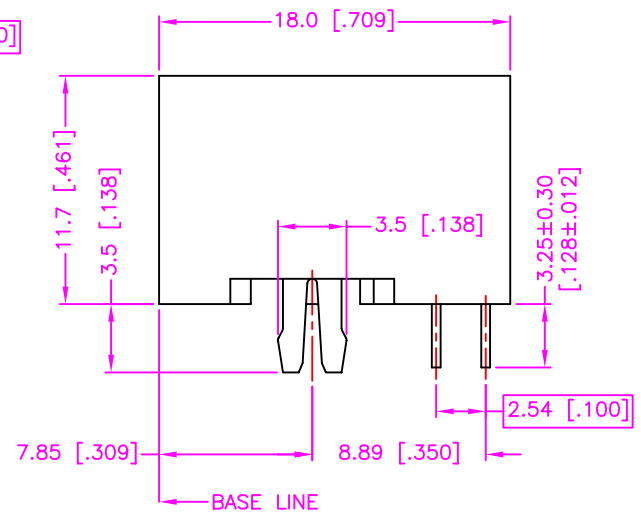
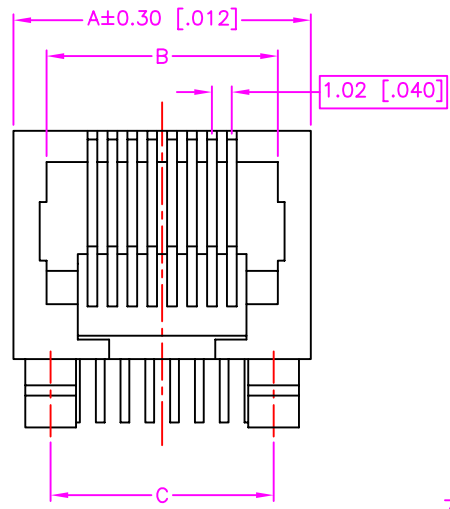

RECOMMEND P.C.B. LAYOUT
TOP VIEW

MATERIALS

1. HOUSING : P.B.T (UL 94V-0), BLACK.
2. TERMINAL : Ø0.45mm PHOSPHOR BRONZE.

SPECIFICATION

1. CURRENT RATING : 1.5 AMP. MAX.
2. DIELECTRIC WITHSTANDING VOLTAGE : 1000V AC R.M.S. FOR ONE MINUTE.
3. INSULATION RESISTANCE : 500M OHMS MIN. AT 500V DC.
4. CONTACT RESISTANCE : 30m OHMS MAX.
5. OPERATING TEMPERATURE : -55°C TO +105°C.
6. DURABILITY : 750 CYCLES.

ORDER INFORMATION :

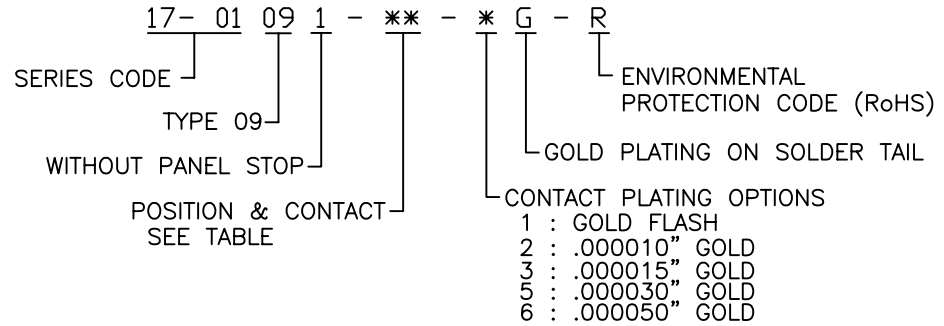

NUMBER OF POSITIONS	NUMBER OF CONTACT	DIMENSIONS		
		A	B	C
6	2/4/6	13.20[.520]	9.90[.390]	10.16[.400]
8	2/4/6/8	15.24[.600]	11.85[.467]	11.43[.450]
TOLERANCE .0=±0.30 [.012] .00=±0.20 [.008] .000=±.XXX .0000=±. ANG.=±3°		DRAWER <i>BEN</i> CHECK <i>NYKXJ</i> APP'D <i>ERJG</i>		Astron WWW.ASTRON.COM.TW NAME MODULAR JACK SIDE ENTRY, ALL PLASTIC
UNITS : mm [inch]		PRODUCT SPEC. 509-0041 C564-0115		
SCALE NONE	SIZE A4	SHEET 1 OF 1	REV. D	DRAW NO. C17-01091-XX-XG-R 08015