

REV.	DESCRIPTION	DATE
A	RELEASE	Aug 14, 2000
B	P/N MODIFY	Jun. 01, 2001
C	RoHS MODIFY	Sep. 27, 2006

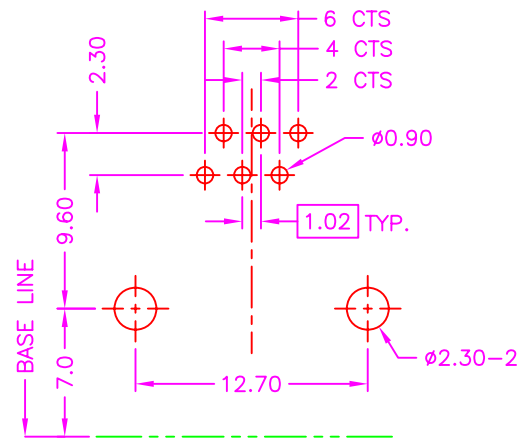
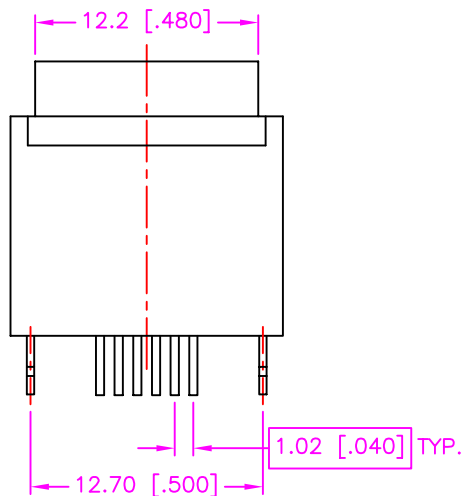
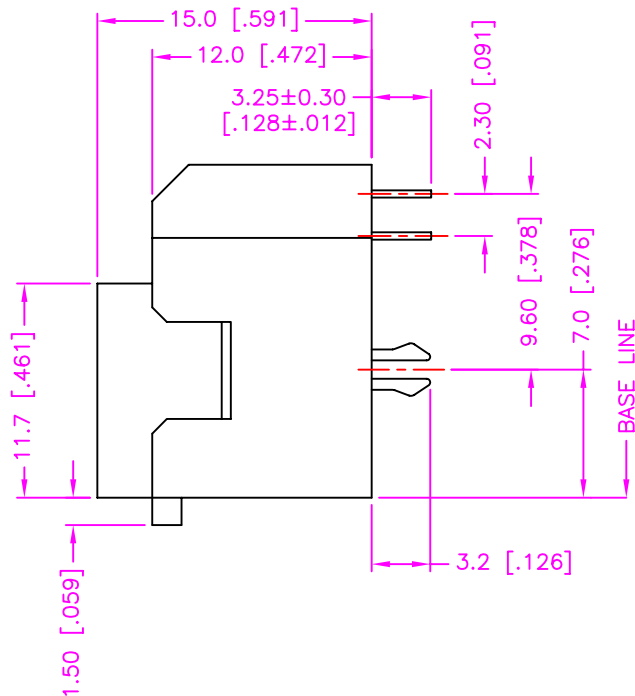
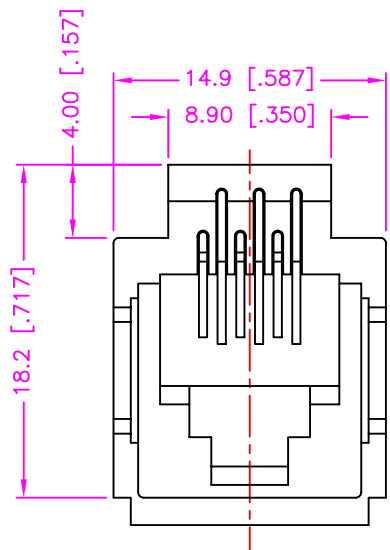

RECOMMEND P.C.B. LAYOUT
TOP VIEW

MATERIALS

- HOUSING : P.B.T (UL 94V-0).
- TERMINAL : $\varnothing 0.45$ mm PHOSPHOR BRONZE.
- METAL PEG : BRASS, TIN PLATING. (t=0.40mm)

SPECIFICATION

- CURRENT RATING : 1.5 AMP. MAX.
- DIELECTRIC WITHSTANDING VOLTAGE : 1000V AC R.M.S. FOR ONE MINUTE.
- INSULATION RESISTANCE : 500M OHMS MIN. AT 500V DC.
- CONTACT RESISTANCE : 30m OHMS MAX.
- OPERATING TEMPERATURE : -55°C TO $+105^{\circ}\text{C}$.
- DURABILITY : 750 CYCLES.

ORDER INFORMATION :

17- 21 01 - ** * - * G - R
 SERIES CODE | TYPE 01 | POSITION & CONTACT | HOUSING COLOR OPTIONS | ENVIRONMENTAL PROTECTION CODE (RoHS) | GOLD PLATING ON SOLDER TAIL | CONTACT PLATING OPTIONS

62 : 6P2C
 64 : 6P4C
 66 : 6P6C

BLANK : BLACK (STANDARD)
 G : GRAY

1 : GOLD FLASH
 2 : .000010" GOLD
 3 : .000015" GOLD
 5 : .000030" GOLD

TOLERANCE .0=±.0.30 [.012] .00=±0.20 [.008] .000=±.XXX .0000=±. ANG.=±3°		DRAWER <i>B&N</i>	Astron WWW.ASTRON.COM.TW
UNITS : mm [inch]		CHECK <i>NFKKJ</i>	
SCALE NONE		APP'D <i>BRFB</i>	NAME MODULAR JACK TOP ENTRY, ALL PLASTIC
SIZE A4		PRODUCT SPEC. —	DRAW NO. C17-2101-XXX-XG-R
SHEET 1 OF 1		REV. C	08015 Z09008