

REV.	DESCRIPTION	DATE
A	RELEASE	Mar. 22, 2006
B	DRAW MODIFY	Apr. 07, 2006

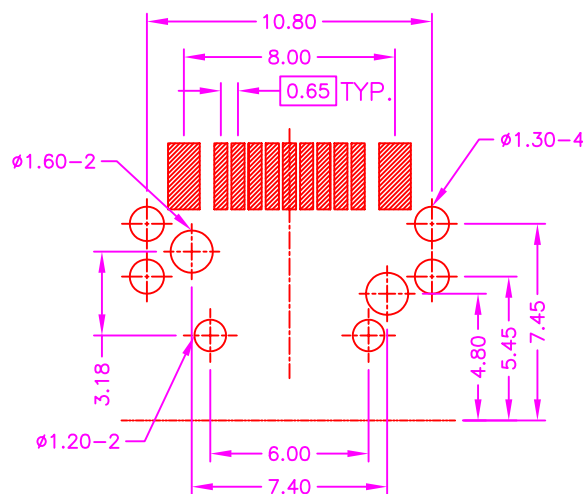
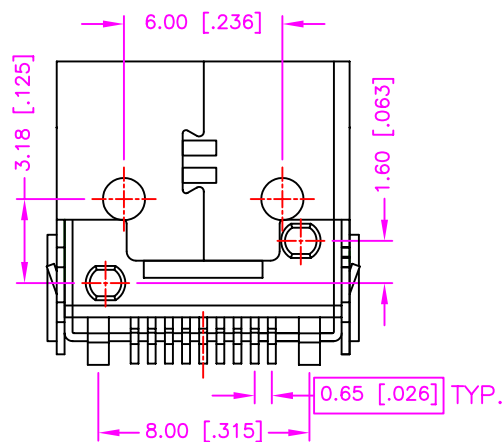
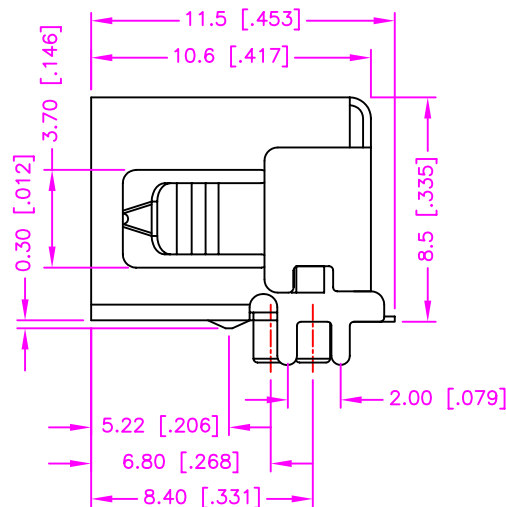
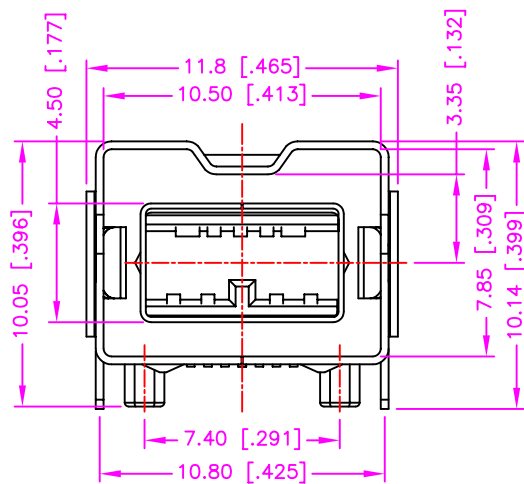

RECOMMEND P.C.B. LAYOUT  
TOP VIEW

### MATERIALS

1. HOUSING : NYLON 9T (UL 94V-0), BLACK.
2. TERMINAL : PHOSPHOR BRONZE. (t=0.20mm)
3. INNER SHELL : BRASS, NICKEL PLATING. (t=0.20mm)
4. OUTER SHELL : BRASS, NICKEL PLATING. (t=0.30mm)

### SPECIFICATION

1. CURRENT RATING : 1.5 AMP. MAX.
2. DIELECTRIC WITHSTANDING VOLTAGE : 100V AC R.M.S. FOR ONE MINUTE.
3. INSULATION RESISTANCE : 100M OHMS MIN. AT 100V DC.
4. CONTACT RESISTANCE : 50m OHMS MAX.
5. OPERATING TEMPERATURE : -40°C TO +85°C.
6. DURABILITY : 1000 CYCLES.
7. MATING FORCE : 0.3 ~ 3.5kgs.
8. UNMATING FORCE : 0.3 ~ 3.5kgs.

### ORDER INFORMATION :

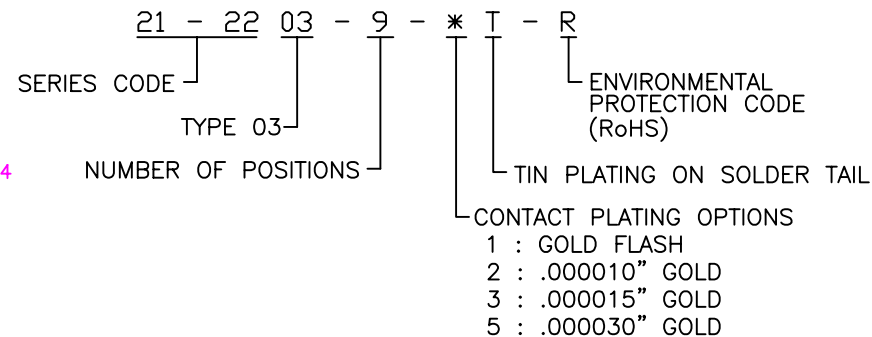

TOLERANCE .0=±0.30 [.012] .00=±0.20 [.008] .000=±.XXX .0000=±. ANG.=±3°		DRAWER <i>ANY</i>	 <b>WWW.ASTRON.COM.TW</b>
		CHECK <i>BEN</i>	
UNITS : mm [inch]		APP'D <i>CRFB</i>	DRAW NO. C21-2203-9-XT-R
SCALE NONE	SIZE A4	PRODUCT SPEC. T-557	REV. B
SHEET 1 OF 1		T0040	